

ARMOURED ONE



SAFETY IS OUR MISSION

We Save Lives By Staying One Step Ahead

Proposal for the Installation of
Shooter Attack Entry Resistant Film
Hernando County School District, Florida

Project No.: TBD



Cover 1
Table of Contents 2

Proposal Documents

Proposal Summary 3
Proposal Approval 6

Armoured One Contract Requirements

Armoured One Florida Business License 7
Form W-9 Request for Taxpayer Identification Number and Certification 13
Certificate of Insurance (Reference) 14

Purchasing Cooperative Participation

The Interlocal Purchasing System (TIPS) Cooperative Certificate 15

Armoured One Qualifications

Armoured One Qualifications 18
Armoured One Qualifications | Management and Executive Team 19
Armoured One Team Qualifications | Florida Project Manager 20
Armoured One Team Qualifications | Supporting Personnel 21
Armoured One Team Qualifications | Installation Team Experience 22
Armoured One Team Qualifications | Training and Certifications 23

Specification and Product Data

Specification (Shooter Attack Film) 24
Product Data (Shooter Attack Film) 31

Key Certifications

ASTM F3561 Notice of Certification - Intertek Testing Lab 34
Miami Dade County Notice of Acceptance 35

Post-Installation and Warranty

Post-Installation and Inspection Guidelines 38
Warranty (Shooter Attack Film) 41
Existing Glass Warranty Consideration 42

Individual Campus Site Audit and Proposal Documents

Campus Site Audits and Quotes (in alphabetical order) 43
Back Cover 175

ARMoured ONE Core Values

Safety: Everyone has the right to a safe community.

Excellence: We do everything to the best of our ability.

Boldness: We courageously bring change in our industry to provide safe communities.

Integrity: Trust is built through uncompromising honesty and integrity.

Quality: Outstanding products and unsurpassed service to meet community needs.



ARMoured ONE

Staying One Step Ahead



Hernando County School District

Location	Estimate Number	Dollar Amount
Brooksville ES	4114	\$28,900.66
Central HS	4141	\$668.60
Chocachatti ES	4117	\$4,465.21
Deltona ES	4147	\$14,714.42
DS Parrot MS	4118	\$7,236.58
Endeavor Academy	4144	\$4,859.48
Explorer K-8	4146	\$7,897.94
F.W Springstead HS	4153	\$26,609.45
Fox Chapel MS	4094	\$18,516.82
Hernando HS	4127	\$18,885.98
JD Floyd ES	4100	\$9,747.63
Moton ES	4131	\$18,241.46
Pine Grove ES	4154	\$19,502.47
Powell MS	4098	\$13,953.56
Springhill ES	4097	\$17,598.17
Suncoast ES	4099	\$5,713.36
Weeki Wachee HS	4134	\$25,539.42
West Hernando MS	4080	\$6,329.81
Westside ES	4087	\$10,107.66
Winding Water K-8	4128	\$20,970.00

Armoured One, LLC is committed to the mission of saving lives. Our goal is to deter, prevent, defend, and protect against Active Shooter or deadly aggressive behavior incidents with solutions that save lives through assessments, training, and protection.

This document is for the exclusive use of the addressee and may contain proprietary, confidential and/or privileged information. If you are not the intended recipient, any use, copying, disclosure, dissemination or distribution is strictly prohibited.

386 N. Midler Ave | Syracuse, NY 13206 | 315-720-4186 | www.armouredone.com





GRAND TOTAL:	\$280,458.68
---------------------	---------------------

Additional Information

Updated Scope

- Central HS
 - Removed exterior windows
- Chocachatti ES
 - Removed Issues 1, 2, 3, 4, 5
- Deltona ES
 - Removed main entrance to enter campus
 - Removed library windows
- Endeavor School
 - Removed first floor parking lot side
 - Removed cafe windows
- Explorer K8
 - Removed cafe windows
- Fox Chapel MS
 - Removed Bldg 1, 2, 5, 10
- FW Springstead HS
 - Removed 199 circulation windows
 - Removed Building 10 parent drop off windows
- Hernando HS
 - Kept Issue 1, 2, 3, 4, & 5
- Pine Grove ES
 - Removed cafe windows on Issue 4
 - Removed media center windows
 - Removed admin windows
- West Hernando MS
 - Removed admin courtyard windows
 - Removed building one parking lot side windows
 - Removed building two next to electrical windows
 - Removed building five guidance windows
 - Removed building five parking lot side windows
 - Removed cafe parking lot side windows

Armoured One, LLC is committed to the mission of saving lives. Our goal is to deter, prevent, defend, and protect against Active Shooter or deadly aggressive behavior incidents with solutions that save lives through assessments, training, and protection.

This document is for the exclusive use of the addressee and may contain proprietary, confidential and/or privileged information. If you are not the intended recipient, any use, copying, disclosure, dissemination or distribution is strictly prohibited.

386 N. Midler Ave | Syracuse, NY 13206 | 315-720-4186 | www.armouredone.com





-
- Weeki Wachee HS
 - Removed 500 & 600 hallways

Armoured One, LLC is committed to the mission of saving lives. Our goal is to deter, prevent, defend, and protect against Active Shooter or deadly aggressive behavior incidents with solutions that save lives through assessments, training, and protection.

This document is for the exclusive use of the addressee and may contain proprietary, confidential and/or privileged information. If you are not the intended recipient, any use, copying, disclosure, dissemination or distribution is strictly prohibited.

386 N. Midler Ave | Syracuse, NY 13206 | 315-720-4186 | www.armouredone.com





Total Contract Amount:

\$280,458.68

Armoured One Authorized Representative:

Tom Connellan

Authorized Signature:

Date:

May 14, 2026



**Hernando County School District
Authorized Representative:**

Authorized Signature:

Date:

Terms:

Invoicing Procedure: Armoured One will invoice after substantial completion of each campus with 30-day net terms for payment.

Coordination with Maintenance: Once we receive a purchase order, we'll assign a project manager to this job. They'll coordinate with you and your maintenance team to schedule installation dates for each school, ensuring everything aligns with your plans



Approved as to Legal Sufficiency
Caroline I. Mockler, Esq.
Staff Counsel, HCSD
5:41 pm, 05/14/2026

Proposal Approval



FLORIDA DEPARTMENT OF STATE
Division of Corporations

May 19, 2023

COGENCYGLOBAL

Qualification documents for ARMoured ONE, LLC were filed on May 18, 2023, and assigned document number M23000006510. Please refer to this number whenever corresponding with this office.

Your limited liability company is authorized to transact business in Florida as of the file date.

The certification you requested is enclosed.

To maintain "active" status with the Division of Corporations, an annual report must be filed yearly between January 1st and May 1st beginning in the year following the file date or effective date indicated above. If the annual report is not filed by May 1st, a \$400 late fee will be added.

A Federal Employer Identification Number (FEI/EIN) will be required when this report is filed. Apply today with the IRS online at:

<https://sa.www4.irs.gov/modiein/individual/index.jsp>

Please notify this office if the limited liability company address changes, it is the responsibility of the corporation to notify this office.

Should you have any questions regarding this matter, please contact this office at the address given below.

Corey Pettway
Regulatory Specialist II
CoT
Division of Corporations

Letter Number: 523A00011515

Account number: I20000000088

Amount charged: 155.00

www.sunbiz.org

Division of Corporations - P.O. BOX 6327 -Tallahassee, Florida 32314





State of Florida



Department of State

I certify the attached is a true and correct copy of the application by ARMoured ONE, LLC, a New York limited liability company, authorized to transact business within the state of Florida on May 18, 2023, as shown by the records of this office.

The document number of this limited liability company is M23000006510.

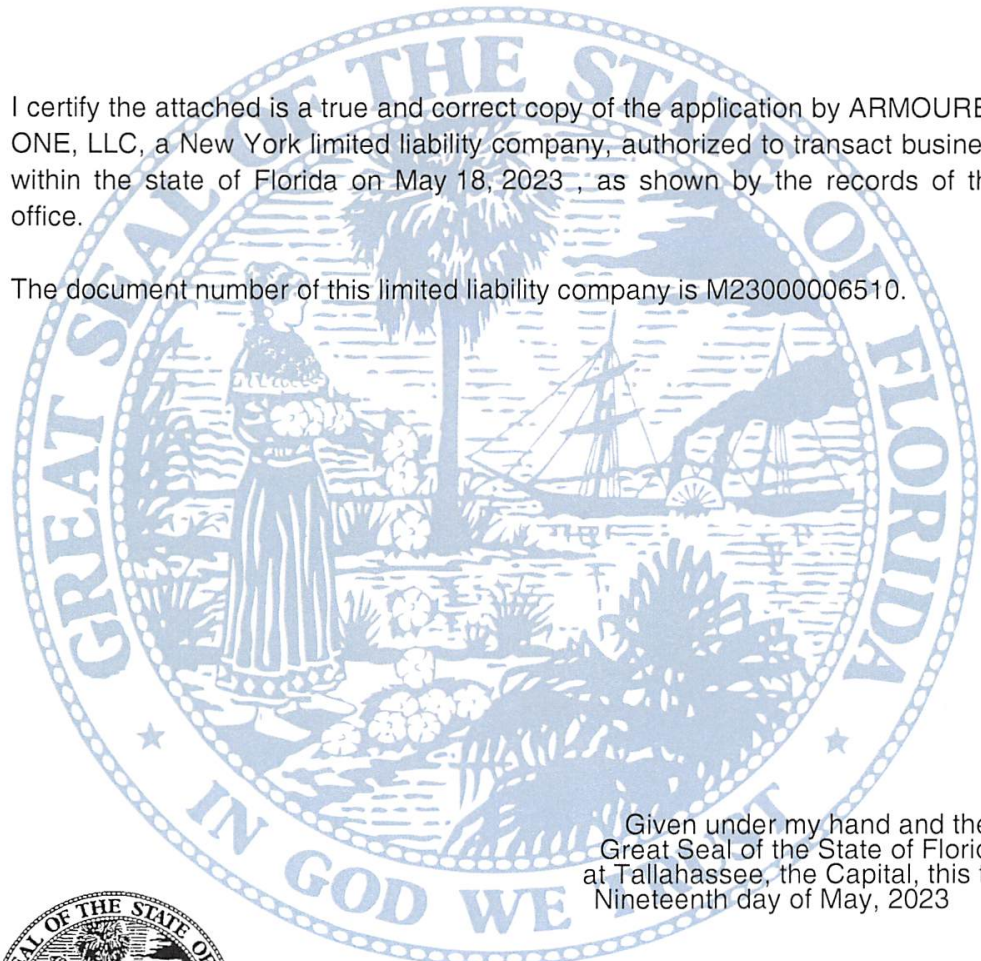

Given under my hand and the Great Seal of the State of Florida at Tallahassee, the Capital, this the Nineteenth day of May, 2023



CR2E022 (01-11)

Cord Byrd
Secretary of State



COVER LETTER

**TO: Registration Section
Division of Corporations**

SUBJECT: Armoured One, LLC
Name of Limited Liability Company

The enclosed "Application by Foreign Limited Liability Company for Authorization to Transact Business in Florida," Certificate of Existence, and check are submitted to register the above referenced foreign limited liability company to transact business in Florida.

Please return all correspondence concerning this matter to the following:

Deepa Francis
Name of Person

Armoured One, LLC
Firm/Company

386 N Midler Ave
Address

Syracuse, NY 13206
City/State and Zip Code

dfrancis@armouredone.com
E-mail address: (to be used for future annual report notification)

For further information concerning this matter, please call:

Deepa Francis at () 315 883 2042
Name of Contact Person Area Code Daytime Telephone Number

MAILING ADDRESS:
Division of Corporations
Registration Section
P.O. Box 6327
Tallahassee, FL 32314

STREET ADDRESS:
Division of Corporations
Registration Section
Clifton Building
2661 Executive Center Circle
Tallahassee, FL 32301

Enclosed is a check for the following amount:
Please make check payable to: **FLORIDA DEPARTMENT OF STATE**

- \$125.00 Filing Fee
- \$130.00 Filing Fee & Certificate of Status
- \$155.00 Filing Fee & Certified Copy
- \$160.00 Filing Fee, Certificate of Status & Certified Copy



APPLICATION BY FOREIGN LIMITED LIABILITY COMPANY FOR AUTHORIZATION TO TRANSACT BUSINESS IN FLORIDA

IN COMPLIANCE WITH SECTION 605.0902, FLORIDA STATUTES, THE FOLLOWING IS SUBMITTED TO REGISTER A FOREIGN LIMITED LIABILITY COMPANY TO TRANSACT BUSINESS IN THE STATE OF FLORIDA:

1. Armoured One, LLC
(Name of Foreign Limited Liability Company; must include "Limited Liability Company," "L.L.C.," or "LLC.")

If name unavailable, enter alternate name adopted for the purpose of transacting business in Florida. The alternate name must include "Limited Liability Company," "L.L.C.," or "LLC.")

2. NY
(Jurisdiction under the law of which foreign limited liability company is organized)

3. 46-1864542
(FEI number, if applicable)

4. Not Applicable
(Date first transacted business in Florida, if prior to registration.)
(See sections 605.0904 & 605.0905, F.S. to determine penalty liability)

5. 386 N Midler Ave
(Street Address of Principal Office)
Syracuse
NY, 13206

6. 386 N Midler Ave
(Mailing Address)
Syracuse
NY, 13206

7. Name and street address of Florida registered agent: (P.O. Box NOT acceptable)

Name: Cogency Global Inc.

Office Address: 115 North Calhoun St. Suite 4

Tallahassee, Florida 32301
(City) (Zip code)

FILED
2023 MAY 18 PM 1:37
SECRETARY OF STATE
TALLAHASSEE, FL

Registered agent's acceptance:

Having been named as registered agent and to accept service of process for the above stated limited liability company at the place designated in this application, I hereby accept the appointment as registered agent and agree to act in this capacity. I further agree to comply with the provisions of all statutes relative to the proper and complete performance of my duties, and I am familiar with and accept the obligations of my position as registered agent.

Aileen McKeown
(Registered agent's signature)



8. For initial indexing purposes, list names, title or capacity and addresses of the primary members/managers or persons authorized to manage [up to six (6) total]:

<u>Title or Capacity:</u>	<u>Name and Address:</u>	<u>Title or Capacity:</u>	<u>Name and Address:</u>
<input type="checkbox"/> Manager	Name: <u>Lisa Henderson</u>	<input type="checkbox"/> Manager	Name: <u>Deeпа Francis</u>
<input type="checkbox"/> Member	Address: <u>386 N Midler Ave</u>	<input type="checkbox"/> Member	Address: <u>386 N Midler Ave</u>
<input checked="" type="checkbox"/> Authorized	<u>Syracuse, NY 13206</u>	<input checked="" type="checkbox"/> Authorized	<u>Syracuse, NY 13206</u>
Person	_____	Person	_____
<input type="checkbox"/> Other _____	<input type="checkbox"/> Other _____	<input type="checkbox"/> Other _____	<input type="checkbox"/> Other _____
<input type="checkbox"/> Manager	Name: _____	<input type="checkbox"/> Manager	Name: _____
<input type="checkbox"/> Member	Address: _____	<input type="checkbox"/> Member	Address: _____
<input type="checkbox"/> Authorized	_____	<input type="checkbox"/> Authorized	_____
Person	_____	Person	_____
<input type="checkbox"/> Other _____	<input type="checkbox"/> Other _____	<input type="checkbox"/> Other _____	<input type="checkbox"/> Other _____
<input type="checkbox"/> Manager	Name: _____	<input type="checkbox"/> Manager	Name: _____
<input type="checkbox"/> Member	Address: _____	<input type="checkbox"/> Member	Address: _____
<input type="checkbox"/> Authorized	_____	<input type="checkbox"/> Authorized	_____
Person	_____	Person	_____
<input type="checkbox"/> Other _____	<input type="checkbox"/> Other _____	<input type="checkbox"/> Other _____	<input type="checkbox"/> Other _____

Important Notice: Use an attachment to report more than six (6). The attachment will be imaged for reporting purposes only. Non-indexed individuals may be added to the index when filing your Florida Department of State Annual Report form.

9. Attached is a certificate of existence, no more than 90 days old, duly authenticated by the official having custody of records in the jurisdiction under the law of which it is organized. (If the certificate is in a foreign language, a translation of the certificate under oath of the translator must be submitted)

10. This document is executed in accordance with section 605.0203 (1) (b), Florida Statutes. I am aware that any false information submitted in a document to the Department of State constitutes a third degree felony as provided for in s.817.155, F.S.

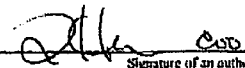

 Signature of an authorized person

 Lisa Henderson, CEO

 Typed or printed name of signer



STATE OF NEW YORK

DEPARTMENT OF STATE

Certificate of Status

I, ROBERT J. RODRIGUEZ, Secretary of State of the State of New York and custodian of the records required by law to be filed in my office, do hereby certify that upon a diligent examination of the records of the Department of State, as of the date and time of this certificate, the following entity information is reflected:

Entity Name:	ARMOURED ONE, LLC
DOS ID Number:	4350928
Entity Type:	DOMESTIC LIMITED LIABILITY COMPANY
Entity Status:	EXISTING
Date of Initial Filing with DOS:	01/25/2013
Statement Status:	CURRENT
Statement Due Date:	01/31/2023

No information is available from this office regarding the financial condition, business activity or practices of this entity.

WITNESS my hand and official seal of the Department of State, at the City of Albany, on May 18, 2023 at 03:21 P.M.

ROBERT J. RODRIGUEZ, Secretary of State



By Brendan C. Hughes
Executive Deputy Secretary of State

Authentication Number: 100003534197 To Verify the authenticity of this document you may access the Division of Corporation's Document Authentication Website at <http://ecorp.dos.ny.gov>





Form **W-9**
(Rev. March 2024)
Department of the Treasury
Internal Revenue Service

Request for Taxpayer Identification Number and Certification

Go to www.irs.gov/FormW9 for instructions and the latest information.

Give form to the
requester. Do not
send to the IRS.

Before you begin. For guidance related to the purpose of Form W-9, see *Purpose of Form*, below.

Print or type. See Specific Instructions on page 3.	1 Name of entity/individual. An entry is required. (For a sole proprietor or disregarded entity, enter the owner's name on line 1, and enter the business/disregarded entity's name on line 2.) Armoured One LLC	
	2 Business name/disregarded entity name, if different from above.	
	3a Check the appropriate box for federal tax classification of the entity/individual whose name is entered on line 1. Check only one of the following seven boxes. <input type="checkbox"/> Individual/sole proprietor <input type="checkbox"/> C corporation <input type="checkbox"/> S corporation <input type="checkbox"/> Partnership <input type="checkbox"/> Trust/estate <input checked="" type="checkbox"/> LLC. Enter the tax classification (C = C corporation, S = S corporation, P = Partnership) P Note: Check the "LLC" box above and, in the entry space, enter the appropriate code (C, S, or P) for the tax classification of the LLC, unless it is a disregarded entity. A disregarded entity should instead check the appropriate box for the tax classification of its owner. <input type="checkbox"/> Other (see instructions)	4 Exemptions (codes apply only to certain entities, not individuals; see instructions on page 3): Exempt payee code (if any) _____ Exemption from Foreign Account Tax Compliance Act (FATCA) reporting code (if any) _____ <i>(Applies to accounts maintained outside the United States.)</i>
	3b If on line 3a you checked "Partnership" or "Trust/estate," or checked "LLC" and entered "P" as its tax classification, and you are providing this form to a partnership, trust, or estate in which you have an ownership interest, check this box if you have any foreign partners, owners, or beneficiaries. See instructions <input type="checkbox"/>	
	5 Address (number, street, and apt. or suite no.). See instructions. 386 North Midler Ave	Requester's name and address (optional)
	6 City, state, and ZIP code Syracuse, NY 13206	
	7 List account number(s) here (optional)	

Part I Taxpayer Identification Number (TIN)

Enter your TIN in the appropriate box. The TIN provided must match the name given on line 1 to avoid backup withholding. For individuals, this is generally your social security number (SSN). However, for a resident alien, sole proprietor, or disregarded entity, see the instructions for Part I, later. For other entities, it is your employer identification number (EIN). If you do not have a number, see *How to get a TIN*, later.

Social security number									
				-					
or									
Employer identification number									
4	6	-	1	8	6	4	5	4	2

Note: If the account is in more than one name, see the instructions for line 1. See also *What Name and Number To Give the Requester* for guidelines on whose number to enter.

Part II Certification

Under penalties of perjury, I certify that:

- The number shown on this form is my correct taxpayer identification number (or I am waiting for a number to be issued to me); and
- I am not subject to backup withholding because (a) I am exempt from backup withholding, or (b) I have not been notified by the Internal Revenue Service (IRS) that I am subject to backup withholding as a result of a failure to report all interest or dividends, or (c) the IRS has notified me that I am no longer subject to backup withholding; and
- I am a U.S. citizen or other U.S. person (defined below); and
- The FATCA code(s) entered on this form (if any) indicating that I am exempt from FATCA reporting is correct.

Certification instructions. You must cross out item 2 above if you have been notified by the IRS that you are currently subject to backup withholding because you have failed to report all interest and dividends on your tax return. For real estate transactions, item 2 does not apply. For mortgage interest paid, acquisition or abandonment of secured property, cancellation of debt, contributions to an individual retirement arrangement (IRA), and, generally, payments other than interest and dividends, you are not required to sign the certification, but you must provide your correct TIN. See the instructions for Part II, later.

Sign Here	Signature of U.S. person <i>[Signature]</i>	Director of Finance	Date	10/13/2025
------------------	--	---------------------	------	------------

General Instructions

Section references are to the Internal Revenue Code unless otherwise noted.

Future developments. For the latest information about developments related to Form W-9 and its instructions, such as legislation enacted after they were published, go to www.irs.gov/FormW9.

What's New

Line 3a has been modified to clarify how a disregarded entity completes this line. An LLC that is a disregarded entity should check the appropriate box for the tax classification of its owner. Otherwise, it should check the "LLC" box and enter its appropriate tax classification.

New line 3b has been added to this form. A flow-through entity is required to complete this line to indicate that it has direct or indirect foreign partners, owners, or beneficiaries when it provides the Form W-9 to another flow-through entity in which it has an ownership interest. This change is intended to provide a flow-through entity with information regarding the status of its indirect foreign partners, owners, or beneficiaries, so that it can satisfy any applicable reporting requirements. For example, a partnership that has any indirect foreign partners may be required to complete Schedules K-2 and K-3. See the Partnership Instructions for Schedules K-2 and K-3 (Form 1065).

Purpose of Form

An individual or entity (Form W-9 requester) who is required to file an information return with the IRS is giving you this form because they



ARMOURD ONE

Staying One Step Ahead



The Interlocal Purchasing System

Purchasing Made Personal



Printed: May 14, 2026
www.armouredone.com/



Armoured One LLC

EMAIL PO & VENDOR QUOTE TO: TIPSPO@TIPS-USA.COM

PO AND QUOTE MUST REFERENCE VENDOR'S TIPS CONTRACT NUMBER
ATTACH PO AS A PDF - ONLY ONE PO (WITH QUOTE) PER ATTACHMENT

PAYMENT TO

ADDRESS **386 N Midler Avenue**
CITY **Syracuse**
STATE **NY**
ZIP **13206**

TIPS CONTACT

NAME **Charlie Martin**
PHONE **(866) 839-8477**
FAX **(866) 839-8472**
EMAIL **tips@tips-usa.com**

DISADVANTAGED/MINORITY/WOMAN BUSINESS ENTERPRISE: **N** HUB: **N**

SERVING STATES

AL | AK | AZ | AR | CA | CO | CT | DE | DC | FL | GA | HI | ID | IL | IN | IA | KS | KY | LA | ME | MD | MA | MI | MN | MS | MO | MT | NE | NV | NH | NJ | NM | NY | NC | ND | OH | OK | OR | PA | RI | SC | SD | TN | TX | UT | VT | VI | VA | WA | WI | WY | PR

Overview

Armoured One LLC is a security-focused company dedicated to enhancing safety through high-performance security solutions. We specialize in providing cutting-edge products and expert services designed to fortify buildings against threats. Our advanced security film offers an added layer of protection, reinforcing glass to withstand forced entry, impact, and even ballistic threats. In addition to supplying top-tier security film, our team provides professional installation services, ensuring seamless application for maximum effectiveness. Whether safeguarding schools, commercial properties, or government facilities, we are committed to delivering superior security solutions that help protect lives and assets.



AWARDED CONTRACTS

"View EDGAR Doc" on Website

Contract	Commodity	Exp Date	EDGAR
220601	Consulting and Other Related Services	08/31/2027	Yes
24020301	Fire, Firearm, and Active Shooter Safety and Security Solutions (NON-JOC)	04/30/2027	Yes
250106	Technology Solutions Products and Services	05/31/2030	Yes
250604	Glass, Services, Break Repair, Replacement, and Miscellaneous Glass	08/31/2028	Yes

CONTACTS BY CONTRACTS

220601

Name	Title	Phone	Email
Lisa Henderson	COO	(315) 720-4186	lisah@armouredone.com
Deepa Francis	Admin Fee	(315) 720-4186	ap@armouredone.com
Vitaliy Novytskyy	PO Contact	(315) 720-4186	vnovytskyy@armouredone.com

24020301

Name	Title	Phone	Email
Vitaliy Novytskyy	Sr. Account Manager	(605) 759-5081	vnovytskyy@armouredone.com
Lisa Henderson	COO	(315) 726-4186	lisah@armouredone.com
Deepa Francis	Admin Fee	(315) 726-4186	ap@armouredone.com

250106

Name	Title	Phone	Email
Vitaliy Novytskyy	Manager	(605) 759-5081	vnovytskyy@armouredone.com
Emma Kobyljanskyi	Director	(315) 883-2036	ekobyljanskyi@armouredone.com
Deepa Thalappillil	Admin Fee	(315) 883-2042	dthalappillil@armouredone.com



250604

Name	Title	Phone	Email
Vitaliy Novytskyy	Manager	(315) 883-2049	vnovytskyy@armouredone.com
Emma Kobylanskyi	Director	(315) 883-2036	ekobylanskyi@armouredone.com
Deepa Thalappillil	Admin Fee	(315) 883-2042	dthalappillil@armouredone.com



Our Mission Is Clear: Save Lives During An Active Shooter Attack

Armoured One is a privately owned company that specializes exclusively in security solutions, including planning and preparedness, active shooter training, and the production of laminated security glazing and security film, primarily for educational facilities. Our products are specifically designed to slow down an active shooter. By leveraging the insights and expertise of subject matter experts—ranging from law enforcement and military personnel to first responders, school administrators, architects, engineers, contractors, and material scientists—Armoured One has established itself as a leading authority in protecting against active shooter incidents.

More than just a glass and film manufacturer, Armoured One has tirelessly lobbied for effective change in school safety requirements, educated school administrators on reacting to dangerous threats, and trained law enforcement to respond faster and more efficiently to save lives.

Key Certifications:

- ASTM F3561: Standard Test Method for Forced-Entry-Resistance of Fenestration Systems After Simulated Active Shooter Attack Certification, Level 1 on 24"x24" specimen (*Glass Only for film since not full assembly*)
- FILTI Testing and Development FTD-SA Active Shooter Attack Certification, Class 1
- Miami Dade County Approved

Manufacturer-Certified Installation

Armoured One manufactures the film products proposed under this RFP. All Armoured One installers are trained directly by the manufacturer — by Armoured One's own Quality Assurance and Field Services Training Specialist. No third-party certification program is required because Armoured One is the certifying authority. This is not a distinction any competing general film contractor can match.

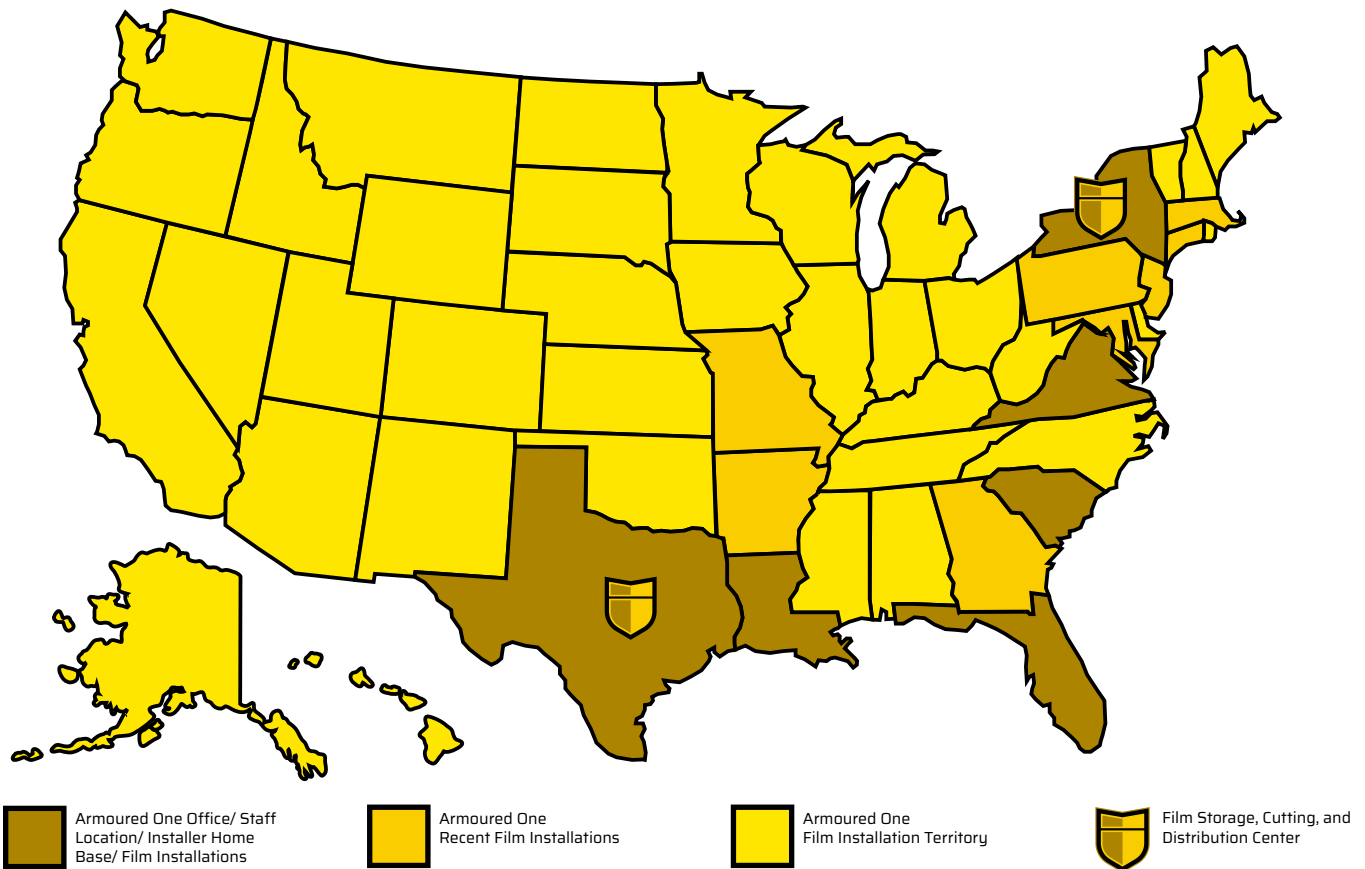

Not all film products are created equal. Many of the film products currently available on the market have evolved from safety films designed primarily to guard against adverse weather, accidental damage, or burglary and vandalism. These situations typically involve less forceful or sustained attacks compared to those posed by determined active shooters or assailants.

Similarly, the common test methods used to test the performance of these films against attacks are not all equally effective. Films can behave dramatically differently when subjected to attack after being perforated or shot, making them easier to tear and breach. If existing tests were sufficient for assessing performance in an active shooter scenario, there would not have been a need for the ASTM to establish the ASTM F3561 standard.



Tom Czyz
Founder & Chief Executive Officer
tom@armouredone.com
(315) 720-4186

Maria Czyz
President | One Training
maria@armouredone.com
(315) 720-4186



Lisa Henderson
Chief Operating Officer
lisah@armouredone.com
(315) 883-2036

Emma Kobylanskyi
National Director of Sales
ehenderson@armouredone.com
(315) 883-2036



Tom Connellan
Southeast Sales Director
tconnellan@armouredone.com
(315) 382-7785

Dan Luttrell, AIA, LEED AP, RA (TX 19774)
Director of Architectural Business Development
dluttrell@armouredone.com
(315) 234-4874



Dmytro "Dima" Kobylanskyi
Director of Manufacturing Operations
dkobylsndkyi@armouredone.com
(315) 883-2036

Travis Forrester
Director of Security Assessments
tforrester@armouredone.com
(315) 820-5211



Jared Henderson
Environmental Health & Safety Coordinator
jhenderson@armouredone.com
(315) 720-4186

Steven Guerin, Ph.D.
Lead Research & Development Specialist
sguerin@armouredone.com
(315) 234-7768



Jaron Hamby
Quality Assurance & Field Services
Training Specialist
jhamby@armouredone.com
(315) 800-0299

Maya Howerton
Research & Development Specialist
mhowerton@armouredone.com
(315) 720-4186



Vitaliy Novytskyi
Senior Glass Account Manager
vnovytskyi@armouredone.com
(605) 759-5081

Tracy Haynes
Senior Glass Account Manager
thaynes@armouredone.com
(315) 352-4068 Ext. 112



Jack Darstein
Film Account Manager | Texas Region
jdarstein@armouredone.com
(315) 883-2028

Austin Williams
Film Account Manager | Northeast Region
awilliams@armouredone.com
(315) 883-2066 Ext. 109



Joshua Dorschner
Film Account Manager | Southeast Region
jdorschner@armouredone.com
(315) 720-4186

Deepa Thalappillil
Director of Finance
dfrancis@armouredone.com
(315) 883-2042



Curtis Morehead
Florida Field Services Project Manager
cmorehead@armouredone.com
(315) 234-4912

Aaron Butterfield
Virginia Field Services Project Manager
abutterfield@armouredone.com
(315) 352-4068



Valentin Morin III
Texas Field Services Project Manager
vmorin@armouredone.com
(210) 710-1311

Loudon Smith
Texas Field Services Project Manager
lsmith@armouredone.com
(315) 849-1486





Curtis Morehead

Florida Field Services Project Manager

cmorehead@armouredone.com | (315) 234-4912 | Lakeland, Florida

Professional Background and Experience

Curtis brings 7+ years of construction-related project management experience across industrial, commercial, and public projects, including 3+ years specializing specifically in security window film and security glazing. He has directly overseen 300+ security and safety upgrade projects, primarily within K-12 school districts and other occupied public facilities throughout the Southeast Region.

His project management experience includes multi-site programs involving scheduling, installation oversight, quality control, logistics coordination, and direct communication with school district personnel, custodial teams, and project stakeholders at all levels.

Florida K-12 Districts Managed

Curtis has personally overseen security film projects in the following Florida school districts:

- Lee County Schools
- Polk County Public Schools
- Martin County School District
- Santa Rosa County School District
- Multiple private school systems across Florida

Project Manager Resume Summary

Total PM Experience	7+ years construction and project management across industrial, commercial, and public sector facilities.
Security Film Specialization	3+ years dedicated to security window film and security glazing installation management.
Projects Managed	300+ security and safety upgrade projects. Primarily K-12 school districts and occupied public facilities in the Southeast Region.
Florida Districts	Lee County, Polk County, Martin County, Santa Rosa County, and multiple private school systems.
Scheduling & Coordination	Manages multi-site district programs including crew dispatch, material logistics, district access coordination, and schedule management around the academic calendar. Communicates directly with school administrators, facilities directors, custodial staff, and district maintenance personnel.
Quality Control	Conducts pre-installation site walks, supervises installation to Armoured One manufacturer specifications, and verifies DOWSIL 995 sealant application before project sign-off. Works alongside QA Specialist Jaron Hamby on quality audits.
Work Order & Invoicing	All work performed strictly within written work orders. No out-of-scope work without prior written authorization from district maintenance staff — fully consistent with Pasco County Schools' requirement for Robert MacNeill pre-approval on all additional scope. Curtis also handles invoicing directly with the primary contact at each school, ensuring accurate and timely billing tied to completed work orders.
Occupied Building Experience	Specializes in managing security film installation in active, occupied school environments. Places strong emphasis on minimizing disruption to campus operations, student safety, and professional conduct on school grounds at all times.



Jaron Hamby

Quality Assurance and Field Services Training Specialist

jhamby@armouredone.com | (315) 800-0299

Role

Performs routine visual inspections and physical quality checks of completed project sites to ensure installations meet Armoured One's manufacturer standards. Assists in installer development and ongoing field training to maintain consistency and installation quality across all active projects.



Tom Connellan

Southeast Regional Sales Director

tconnellan@armouredone.com | (315) 382-7785

Role

Primary account-level contact for the District School Board of Pasco County. Tom manages the overall relationship between Armoured One and the District -- serving as the point of contact for contract-level matters, scope discussions, pricing, renewals, and any escalations. All district-level communications on contract performance and relationship management flow through Tom.



Jared Henderson

Environmental Health and Safety Coordinator

jhernderson@armouredone.com | (315) 720-4186

Role

Dedicated EHS oversight for all Armoured One field operations. Ensures school site safety compliance across all active installation projects.



Dan Luttrell, AIA, LEED AP, RA

Director of Architectural Business Development

dluttrell@armouredone.com | (315) 234-4874

Role

Strong technical knowledge and architectural background enables effective communication of design value to clients, partners, and stakeholders. Passionate about building partnerships that foster innovation, cultivating lasting client relationships, and educating architects, owners, and contractors to promote Armoured One's mission and vision of saving lives by providing active shooter security in every school.



Installation Team Experience

Armoured One’s Florida installation team operates under the direct supervision of Curtis Morehead, Florida Field Services Project Manager. All team members are trained exclusively by Armoured One’s internal QA and training staff. No subcontractors are used on any Armoured One project -- every installer performing work under this contract will be a direct Armoured One employee.

Installation Team Members

All seven Florida installation team members have been fingerprinted, background checked, and carry valid Florida Public Schools contractor badges required for work on school campuses. Pasco County Schools will have immediate verified access for every crew member dispatched under this contract.

Bailey Czyz	Lead Installer	Fingerprinted. Background checked. Florida Public Schools contractor badge.
Antonio Gonzalez	Installer	Fingerprinted. Background checked. Florida Public Schools contractor badge.
Noah Czyz	Installer	Fingerprinted. Background checked. Florida Public Schools contractor badge.
Savion Lott	Installer	Fingerprinted. Background checked. Florida Public Schools contractor badge.
Jaden Johnson	Installer	Fingerprinted. Background checked. Florida Public Schools contractor badge.
Thomas Martinez	Installer	Fingerprinted. Background checked. Florida Public Schools contractor badge.
Chris D’Agostino	Installer	Fingerprinted. Background checked. Florida Public Schools contractor badge.

Team Experience and Capabilities

Field	Detail
Average Experience	Approximately 4 years hands-on field experience per team member.
Film Specialization	All team members have extensive experience installing, removing, replacing, and servicing security window film systems within occupied school facilities. All work is performed on 23 mil AOTSF23 film with DOWSIL 995 structural sealant.
Occupied School Protocols	Crews regularly work in active school environments and follow strict operational and safety procedures to minimize disruption. This includes maintaining safe work areas, coordinating with school administration and custodial staff, adhering to district access procedures, and maintaining professional conduct at all times on occupied campuses.
Background Clearances	All team members fingerprinted, background checked, and carry valid Florida Public Schools contractor badges. Ready for immediate campus access.
No Subcontracting	Zero subcontracting on any Armoured One project. Every installer dispatched under this contract is a direct Armoured One employee, trained and supervised under Armoured One’s quality standards.



Internal Manufacturer Training Program

All Armoured One installer training is conducted internally by experienced Armoured One field staff with extensive hands-on knowledge. Because Armoured One manufactures the film product, training is conducted by the manufacturer itself -- not by a third-party certification body. This ensures training is specific to the actual product being installed and reflects real-world field experience, not generic industry guidelines.

Training covers:

- Film properties, layers, and performance characteristics of 23 mil AOTSF23
- Surface preparation and substrate inspection prior to installation
- Application technique for multi-layer security film to ensure optical clarity and bond integrity
- DOWSIL 995 Silicone Structural Sealant -- application, tooling, and cure time management
- Edge sealing and anchoring system installation
- Post-installation inspection criteria and acceptance standards
- Site safety protocols for occupied school environments
- Work order scope management -- no out-of-scope work without prior written authorization
- Customer interaction and professional conduct on school campuses
- Material handling, storage, and site cleanup procedures

Ongoing Quality Assurance

Jaron Hamby, Quality Assurance and Field Services Training Specialist, performs routine visual inspections and physical quality checks of completed project sites across all active Armoured One installations. In addition to quality oversight, Jaron assists in ongoing installer development and field training to maintain consistency across all projects. Installers do not advance to unsupervised field work until quality audit results confirm consistent installation standards.

Company and Product Certifications

Certification / Standard	Held By	Relevance to this Contract
FILTI-SA-Class 1 (ASTM F3561 equivalent)	Armoured One, LLC (as manufacturer)	Film tested to the active shooter attack standard on 1/4" tempered glass - the glass in Florida school entry systems. Installers are trained on this certified product by the manufacturer.
Miami-Dade County Approved (Intertek)	Armoured One, LLC	Florida-specific product approval. Directly applicable to Florida school district procurement.
Florida Public Schools Contractor Badges	All 7 Florida installation team members	All team members fingerprinted, background checked, and badged for immediate verified access to Florida school campuses.
AIA CE Provider (No. 406119336)	Armoured One, LLC	Approved 1 LU/HSW continuing education on attack-resistant openings. Demonstrates recognized subject matter authority at the architect level.
Registered Architect TX 19774 AIA Member 38013289	Dan Luttrell, AIA	Strong technical knowledge and architectural background for assisting with special field conditions.
Environmental Health & Safety Oversight	Jared Henderson, EHS Coordinator	Dedicated EHS oversight for all field operations including school site safety compliance.



SECTION 08 87 00 SECURITY GLAZING FILM

PART 1 - GENERAL

1.1 SECTION INCLUDES

- A. Security Glazing film applied to new and existing glazing assemblies.
- B. Locations: As identified in the Contract Documents.

1.2 RELATED SECTIONS

- A. Drawings and general provision of the Contract, including General and Supplementary Conditions and Division 01 Specification Sections, apply to this Section.

1.3 REFERENCED STANDARDS

- A. American National Standards Institute (ANSI)
 - 1. ANSI Z97.1 - American National Standard for Safety Glazing Materials Used in Buildings, Safety Performance Specifications and Methods of Test; current version.
- B. American Society for Testing and Materials (ASTM)
 - 1. ASTM C1036 – Standard Specification for Flat Glass; current version.
 - 2. ASTM D882 – Standard Test Method for Tensile Properties of Thin Plastic Sheeting; current version.
 - 3. ASTM D1003 – Standard Test Method for Haze and Luminous Transmittance of Transparent Plastics; current version.
 - 4. ASTM D2244 – Standard Practice for Calculation of Color Tolerances and Color Differences from Instrumentally Measured Color Coordinates; current version.
 - 5. ASTM E84 – Standard Test Method for Surface Burning Characteristics of Building Materials; current version.
 - 6. ASTM F3561 - Standard Test Method for Forced-Entry-Resistance of Fenestration Systems After Simulated Active Shooter Attack; current version.
- C. Code of Federal Regulations
 - 1. 16 CFR 1201 - Safety Standard for Architectural Glazing Materials; Consumer Products Safety Commission; current edition.
- D. FILTI Testing and Development
 - 1. FTD SA – FILTI Shooter Attack Certification Testing, FILTI Testing and Development Shooter Attack Certification.
- E. Florida Building Code (Miami-Dade County) for Hurricane Resistance
 - 1. TAS 201 – Impact Test Procedures
 - 2. TAS 202 – Criteria for Testing Impact & Non-Impact Resistant Building Envelope Components Using Uniform Static Air Pressure
 - 3. TAS 203 – Criteria for Testing Products Subject to Cyclic Wind Pressure Loading

1.4 QUALITY ASSURANCE

- A. Manufacturer Qualifications: Glazing film manufacturer specializing in the manufacture of



- security glazing films with minimum 5 years' experience manufacturing products meeting specified requirements.
- B. Installer Qualifications: Direct employees of film manufacturer or manufacturer-approved installers trained in all aspects of film installation.
 - C. Field Mockup: Apply security glazing film in location(s) as directed to verify installation requirements and to demonstrate application effects and qualities of materials and execution.
 - 1. Obtain approval of field samples before continuing with remainder of installation.
 - 2. Maintain mockup during duration of installation in an undisturbed condition as a standard for judging the completed Work.
 - 3. Approved field mockup may become part of the completed Work.
 - D. Film application and performance verification:
 - 1. In addition to only proceeding with reviewed and approved submittals, the awarded contractor/ installer shall certify that the security film installed meets the performance requirements identified within the Contract Documents.
 - 2. Post installation film verification may include the random choosing and removal of up to three pieces of glass with applied film to be tested to verify that film installed meets specification and performance requirements as indicated. Film may need to be removed as part of the verification process.
 - 3. All installed film locations shall be subject to inspection of structural sealant to verify full bite on frames has been achieved.

1.5 SUBMITTALS

- A. Submit under provisions of Division 01.
- B. Test Reports: Detailed reports of full-scale chamber tests to specified criteria, using assemblies commensurate with those required for this project.
- C. Product Data: Manufacturer's data sheets on product to be used, including:
 - 1. Record of product certification for safety requirements.
 - 2. Preparation instructions and recommendations.
 - 3. Storage and handling requirements and recommendations.
 - 4. Installation methods.
- D. Samples: For each film product to be used, minimum size 4-inches by 6-inches, representing actual product.
- E. Manufacturer Guidelines
 - 1. Completed work inspection procedure and viewing guidelines.
 - 2. Post-Installation Inspection Procedures and Agreement
 - a. Curing time and expectations
 - b. Cleaning guidelines
 - c. Other manufacturer specific information



F. Specimen Warranty.

1.6 DELIVERY, STORAGE, AND HANDLING

- A. Store products as directed in manufacturer's unopened packaging until ready for installation.
- B. Store and dispose of solvent-based materials, and materials used with solvent-based materials, in accordance with requirements of authorities having jurisdiction.

1.7 INSTALLATION AND FIELD CONDITIONS

- A. Coordinate installation timeline with General Contractor's and/or Owner's schedule and potential other adjacent work that may create or cause adverse installation conditions.
- B. Maintain environmental conditions (temperature, humidity, and ventilation) within limits recommended by manufacturer for optimum results. Do not install products under environmental conditions outside the manufacturer's absolute limits.
 - 1. Elevation: Installation of film at elevations exceeding 7,000 feet above sea level shall require prior approval from the film manufacturer.
 - 2. Cold climates: Cold ambient temperatures may require extended curing time to allow the adhesive to fully cure and properly bond the film to the glass.

1.8 EXISTING CONDITIONS FOR RETROFIT APPLIED FILM

- A. Glass
 - 1. Verify that all glass receiving film is free of damage, including cracks, chips, or breakage.
 - 2. Security film shall be installed on the innermost surface (protected side) of the glass pane.
 - a. All existing films, stickers, numbering, lettering, signage, paint, or other surface coatings shall be completely removed prior to installation.
 - b. Film shall not be stacked or installed in multiple layers.
 - 3. Glass shall be a minimum of ¼ inch thick. Glass thinner than this may be susceptible to damage or breakage due to installation pressures.
 - 4. Glass size limitations
 - a. No single glass side dimension shall exceed 6 feet.
 - b. The other glass side dimension shall not exceed 11 feet.
 - c. Insulated glass units shall not exceed 40 square feet in surface area.
 - d. For window sizes exceeding limits noted, or for irregular shaped windows, consult with film manufacturer.
 - 5. Film shall be installed only on tempered or annealed glass, and—subject to written confirmation from the film manufacturer—certain laminated glass compositions.
 - 6. Film shall not be installed on plastic, polycarbonate, acrylic, or other non-glass substrates.
 - 7. Film shall not be installed on textured glass, wired glass, skylights, glass block, or other specialty glass surfaces without prior review and written approval from the film manufacturer.
- B. Frame



1. Window and storefront framing shall be metal (aluminum, steel, or equivalent) and shall be free of loose paint, corrosion, rust, or other conditions that may inhibit proper adhesion of the anchoring structural sealant.
 - a. Wood frames are not acceptable, as they cannot be adequately anchored.
 2. Frames shall include a continuous return (shoulder) perpendicular to the glass face, with a minimum bite depth of 3/8 inch, to allow proper anchoring of the structural sealant.
- C. Residential Style Windows
1. General “residential” style windows frames are usually not suitable for security film application, regardless of construction material.
 - a. Residential windows are commonly constructed of 1/8 thick glass panes.
 - b. Residential window frames generally do not have the required shoulder for proper anchoring bite for structural sealant.

1.9 WARRANTY

- A. Provide 15 Year manufacturers replacement warranty to cover film against peeling, cracking, discoloration, and deterioration.

PART 2 - PRODUCTS

2.1 MANUFACTURERS

- A. Acceptable Manufacturer: Armoured One, LLC., 386 North Midler Ave. Syracuse, NY 13206. Tel: 315-720-4186; Email: info@armouredone.com; Web: www.armouredone.com.
 1. Basis of design: Armoured One 23mil Shooter Attack Security Film.
- B. Substitutions: Must provide demonstrated equality to the specified basis of design product and performance requirements.

2.2 SECURITY GLAZING FILM MATERIALS

- A. Security Glazing Film
 1. Single thickness 23 mil (0.023 inch) thick, clear, UV stable, optically transparent, adhesive backed polyester film for permanent bonding to glass.
 - a. Installing multiple layers of thinner film to accomplish the required thickness is not acceptable nor considered equal to the basis of design.
 2. Adhesive Type: Pressure sensitive as recommended by glazing film manufacturer.
 3. Performance Requirements:
 - a. ASTM F3561 - Standard Test Method for Forced-Entry-Resistance of Fenestration Systems After Simulated Active Shooter Attack, Resistance Level 1 (tested on 1/4-inch tempered glass.).
 - 1) Specimen sample shall be evaluated per the requirements of the ASTM F3561 Appendix for Glazing Only Weakening Testing – Non-System Test, as this method is not a systems test and therefore not a certified assembly.



- b. FTD SA – Standard for Shooter Attack certification, Class 1 (tested on 1/4-inch tempered glass).
- c. Tensile Strength: ASTM D-882, 35,000 psi minimum.
- d. Breaking Strength: ASTM D-882, 640 lbs. / inch.
- e. Elongation at Break: ASTM D-882, 230%
- f. Haze: ASTM D1003, <4%
- g. Color b: ASTM D2244, 4.2
- h. Surface Burning Characteristics: Flame spread index of 25, maximum, and smoke developed index of 450, maximum, as tested in accordance with ASTM E84 (Class A).

2.3 SUPPLEMENTAL MATERIALS

- A. Structural Sealant: Per manufacturer's recommendations for the installation application.
 - 1. Acceptable product: DOW Corning DOWSIL795 Silicone Building Sealant, DOWSIL 995 Structural Silicone Sealant, or glazing film manufacturer approved equal.
- B. Provide supplemental anchoring system components as required.
- C. Cleaners, Primers, and Sealers: Types recommended by glazing film manufacturer.

2.4 FIRE RATED SECURITY GLAZING

- A. Fire-rated laminated glass panes can be fabricated to fire-rating resistance ratings of 20-, 45-, 60-, and 90-minute protection as required utilizing security glazing film applied in factory under controlled conditions.
 - 1. Consult with manufacturer if higher rating resistance is required.
- B. Security glazing film may be field applied to existing fire-rated glazing assemblies maintaining the existing fire-resistance protection rating.

2.5 CLARIFICATION ON PERFORMANCE REQUIREMENTS

- A. ASTM F3561 is an assembly test standard.
 - 1. Film applied to glass tested within a new window or door assembly matching the actual completed and installed assembly can be classified as “certified.”
 - 2. Film tested under the glass only portion of test standard for retrofitting to existing glass cannot be classified as “certified” under the standard but can be provided with test results indicating performance achieved by the testing criteria.

PART 3 - EXECUTION

3.1 GENERAL

- A. At existing glazed openings, retrofit glazing assemblies to provide impact resistance and forced/ attack resistance complying with FTD-SA-C1, ANSI Z97.1 and CPSC 16 CFR 1201 Category II.

3.2 PRE-INSTALLATION VERIFICATION

- A. Field-Applied Film: Verify that existing conditions are adequate for proper application and performance of film.



- B. Examine glass and frames, ensure that existing conditions are adequate for proper application and performance of film.
- C. Verify glass is not cracked, chipped, broken, or damaged.
- D. Verify that frames are securely anchored and free of defects.

3.3 PREPARATION

- A. Clean glass of dust, dirt, paint, oil, grease, mildew, mold, and other contaminants that would inhibit adhesion.
- B. Blade the inside surface of window glass to ensure removal of foreign contaminants.
- C. Immediately prior to applying film, thoroughly wash glass with neutral cleaning solution.
- D. Protect adjacent surfaces.
- E. Do not begin installation until substrates have been properly prepared.

3.4 INSTALLATION

- A. Install in accordance with manufacturer's instructions as required to achieve specified performance.
- B. Seams. Seam film only as required to accommodate material sizes, seam without overlaps. Seam orientation to be identified and coordinated in field prior to installation.
- C. Apply bead of structural sealant overlapping 3/8-inch to 1/2-inch of the exposed edge of film and overlapping equally onto the glazing system frame. Allow to cure before cleaning.
- D. Clean glass and excess structural sealants from finished surfaces.
- E. Remove any labels or protective covers. Do not encapsulate anything under the film.

3.5 POST INSTALLATION VERIFICATION

- A. Awarded contractor will be required to verify that film installed meets the requirements highlighted in this bid. By submitting a bid, contractor understands that three pieces of glass, chosen at random, may be removed and tested to verify that film installed meets performance criteria as specified. Glass and/or film may need to be removed as part of the verification process.

3.6 PROTECTION

- A. Protect installed products until completion and final acceptance of project.
- B. Repair or replace damaged products before Substantial Completion.
 - 1. Bubbles and haziness during the curing period is not considered grounds for replacement.
 - 2. Imperfections identified in and consistent with the post-installation inspection procedure and agreement are not considered grounds for replacement.

3.7 CURING

- A. After installation, small bubbles or a hazy appearance may appear due to trapped moisture between the film and the glass. These imperfections typically disappear as the film cures, a process that can take anywhere from a few days to several weeks, depending on temperature, humidity, and other environmental conditions.



- B. Allow the film to cure undisturbed for a smooth, clear finish.
- C. Allow film to cure for up to six weeks prior to initiating inspection review of filmed glass.
- D. If after 11 months of curing, bubbles and haziness persist, replace film.

3.8 INSPECTION

- A. Conduct inspection of completed installation consistent with the manufacturer's post-installation inspection procedure as submitted.

END OF SECTION 08 8753

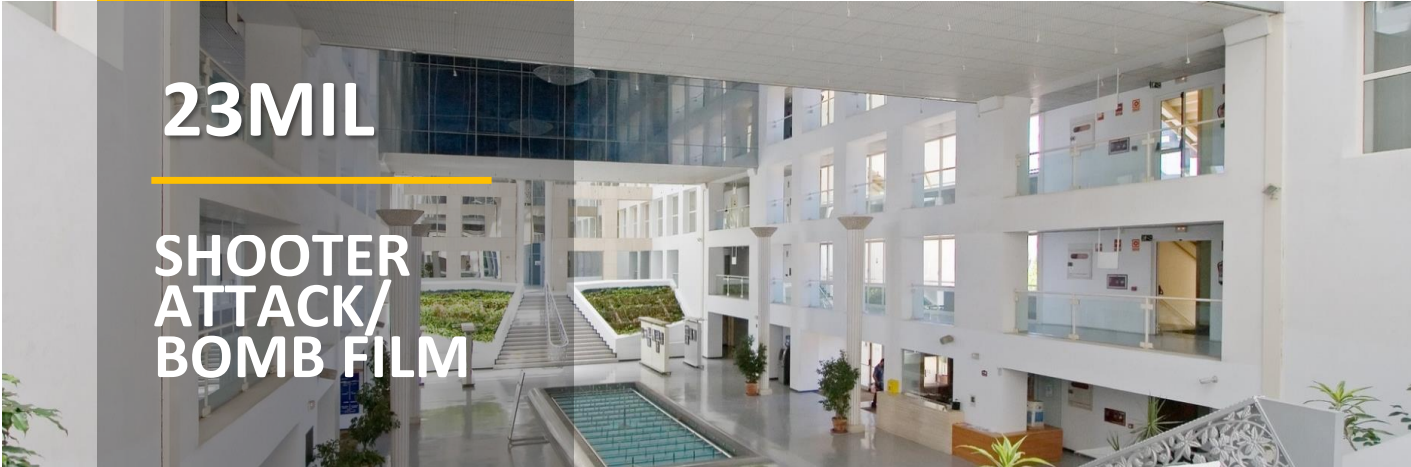

23MIL

SHOOTER ATTACK/ BOMB FILM

Armoured One is a law enforcement - based company that is one of the nation's leading experts in protection from active shooter attacks.

Subject matter experts invented and designed Armoured One's proprietary film to hold its integrity by being stronger and holding together for longer. Our films are much thicker and utilize a patented adhesive technology that allows us to achieve the strength that other films cannot.

The Recognized Leader in Shooter Attack Protection.

When an attacker shoots at a standard window, the glass will shatter instantly, and the intruder is inside in seconds. The added layer of Armoured One's proprietary shooter attack film protection slows down the active shooter and allows emergency response teams more time to arrive at the scene.

There are many "security films" sold in the U.S., but Armoured One is the only one that has passed a Class 1 Shooter Attack Test. That means that every other film sold is not going to protect you from someone with a gun. Every competitor window film will rip very easily after a hole is pierced in it.

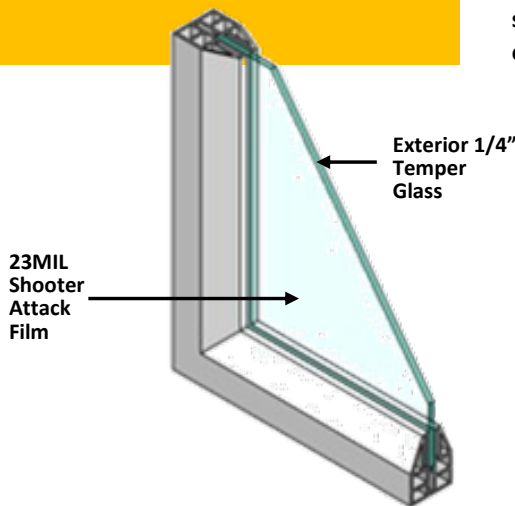

USES

We recommend this for exterior locations, such as windows at vestibules, doors, classroom exterior windows, office windows, large gathering room windows and entry ways.

SPECS

- Installation of our 23MIL film is applied on the inner most surface of your existing glass and anchored to your existing framing.
- Our films are much thicker and utilize a proprietary adhesive technology to achieve the strength that other films cannot.

SHOOTER ATTACK TEST

Armoured One's Security Film has passed a Class 1 Shooter Attack Test where the film was shot 10 times with an AR15 .223 round and then hit with a 100 lb. ram where the glass is struck minimally two (2) times at 50-foot pounds of force by the ram. If the ram penetrates the glass before the completion of the two hits, it is considered a failure. This test is completed by FILTI. This test was created to not only protect the people behind the glass, but also protect decision makers from liability.

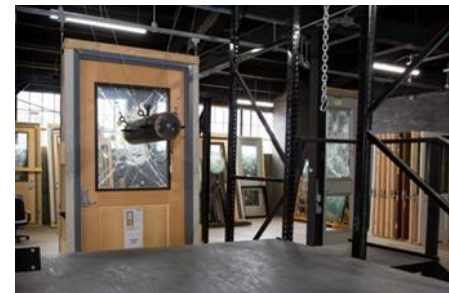



SAFETY GLAZING & GLASS BREAKAGE

ANSI Z97.1 | 16 CFR CPSC 1201



SHOOTER ATTACK CERTIFIED

FTD-SA-LEVEL 1

OPTICAL AND SOLAR PRODUCT SPECIFICATION

No.	Parameter	Test Method	Measurement Tool	Spec	Unit	Comments
1	Haze	ASTM D 1003	Haze Gard Plus	<4	%	Film only
2	Color b	ASTM D 2244	MiniScan XE Plus	4.2	N/A	CIE-LAB D65/10 film only
3	Visible Light Transmitted	Optical and Solar performance...*	CARY 500 Scan Spectropho...**	87	%	Performance data on 1/8" clear glass***
4	Visible Light Reflected (Int)	*	**	12	%	***
5	Visible Light Reflected (Ext)	*	**	12	%	***
6	UV Block	*	**	>99	%	***
7	Total Solar Energy Reflected	*	**	11	%	***
8	Total Solar Energy Transmitted	*	**	77	%	***
9	Total Solar Energy Absorbed	*	**	12	%	***
10	Shading Coefficient	*	**	0.93	N/A	***
11	Total Solar Energy Rejected	*	**	19	%	***
12	Solar Heat Gain Coefficient	*	**	0.81	N/A	***
13	U-Value Winter	*	**	1.03	N/A	***
14	K-Value Winter	*	**	5.85	N/A	***
15	Glare Reduction	*	**	3	&	***

* Optical and Solar performance simulated using LBNL softwares (Optics and WINDOW 5.2) according NFRC methodology

** CARY 500 Scan Spectrophotometer

*** Performance data on 1/8" clear glass



ARMOURED ONE

Staying One Step Ahead

info@armouredone.com | www.armouredone.com | (315) 720-4186



ARMOURED ONE

Staying One Step Ahead



ARMOURED ONE
Staying One Step Ahead

SHOOTER ATTACK CERTIFIED 23MIL FILM



In the US there is an active shooter incident that happens every day and when your building needs to go into lockdown, it is important to have glass that is designed to slow down or deter an attacker from gaining entry with a gun. If you have glass that you're not planning on replacing, then our shooter attack and bomb resistant security film is a great option. It's the first film to be Shooter Attack certified, which means it is designed for bullets to go through, but will still hold the glass together for a much longer time frame than typical safety film. Armoured One's security film was designed by active shooter experts and is military/police grade.

Installation of our 23MIL film is applied on the most inside surface of your existing glass and anchored to your existing framing. Our films are much thicker and utilize a proprietary adhesive technology that allows us to achieve the strength that other films cannot.

ARMOURED ONE SHOOTER ATTACK CERTIFIED 23MIL FILM WITH A 15 YEAR WARRANTY

Break Strength	640 lbs/inch	Highest rated break strength in the industry
Elongation Strength	230%	Highest rated elongation strength in the industry
Tensile Strength at Break	35,000	Highest rated tensile strength in the industry
Peel Strength	10-11 lbs/inch	Highest rated peel strength in the industry
Safety standard for architectural glazing material.	ANSI Z97.1 16CFR CPSC1201	Mandatory Building Code
Shooter Attack Test Method	FTD-SA-C1 (Third Party Tested)	Standard test method for simulating an active shooter attack

info@armouredone.com | www.armouredone.com | (315) 720-4186



ARMOURED ONE
Staying One Step Ahead



intertek
Total Quality. Assured.

Intertek B&C
130 Derry Court
York, PA 17406

Tel +1 717 764 7700
Fax +1 717 764 4129
intertek.com

January 25, 2024

Lisa Henderson
Armoured One Glass, LLC
386 N Midler Ave
Syracuse, NY 13206

RE: Test Results for Job No. Q9347.01-119-12

Dear Lisa Henderson,

Testing was recently conducted on 01/24/24 and 01/25/24 by Intertek^[1] Building & Construction (B&C) on filmed and laminated glazing products at their lab in York, PA.

The specimens were tested in accordance with ASTM F3561. The 1/4" tempered glass with film specimens achieved a level 1 rating and the 5/16" laminated glass specimens achieved a level 4 rating per the performance requirements in the above referenced standard.

Results noted herein are preliminary and have not been reviewed and are therefore subject to change. A comprehensive test report including test specimen description and test data will be forthcoming. If you have any questions, please feel free to contact me at your convenience. This document is a letter of results; it is not a test report.

Sincerely,
INTERTEK B&C

Digitally Signed by: Scott Gladfelter

Scott T. Gladfelter
Senior Project Engineer

STG:aas
cc: Q9347.01-119-12-LOR

^[1] Intertek is a brand name representing the Intertek Group plc legal entities, including but not limited to, Intertek Testing Services NA Inc., Professional Service Industries, Inc. ("INTERTEK-PSI"), **Architectural Testing Inc.** ("INTERTEK-ATI"), and MT Group Inc. ("INTERTEK-MT").

This Letter of Results (LOR) is for the exclusive use of Intertek's Client and is provided pursuant to the agreement between Intertek and its Client. Intertek's responsibility and liability are limited to the terms and conditions of the agreement. Intertek assumes no liability to any party, other than to the Client in accordance with the agreement, for any loss, expense or damage occasioned by the use of this LOR. Only the Client is authorized to permit copying or distribution of this LOR and then only in its entirety. Any use of the Intertek name or one of its marks for the sale or advertisement of the tested material, product or service must first be approved in writing by Intertek. The observations and test results in this LOR are relevant only to the sample(s) tested. This LOR by itself does not imply that the material, product, or service is or has ever been under an Intertek certification program.





DEPARTMENT OF REGULATORY AND ECONOMIC RESOURCES (RER)
BOARD AND CODE ADMINISTRATION DIVISION

NOTICE OF ACCEPTANCE (NOA)

MIAMI-DADE COUNTY
PRODUCT CONTROL SECTION
11805 SW 26 Street, Room 208
Miami, Florida 33175-2474
T (786) 315-2590 F (786) 315-2599
www.miamidade.gov/building

Armoured One, LLC
386 Midler Avenue
Syracuse, NY 13206

SCOPE: This NOA is being issued under the applicable rules and regulations governing the use of construction materials. The documentation submitted has been reviewed and accepted by Miami-Dade County RER-Product Control Section to be used in Miami Dade County and other areas where allowed by the Authority Having Jurisdiction (AHJ).

This NOA shall not be valid after the expiration date stated below. The Miami-Dade County Product Control Section (In Miami Dade County) and/or the AHJ (in areas other than Miami Dade County) reserve the right to have this product or material tested for quality assurance purposes. If this product or material fails to perform in the accepted manner, the manufacturer will incur the expense of such testing and the AHJ may immediately revoke, modify, or suspend the use of such product or material within their jurisdiction. RER reserves the right to revoke this acceptance if it is determined by Miami-Dade County Product Control Section that this product or material fails to meet the requirements of the applicable building code.

This product is approved as described herein and has been designed to comply with the Florida Building Code, including the High Velocity Hurricane Zone.

DESCRIPTION: AOTSF 23 Shooter Attack Film

APPROVAL DOCUMENT: Drawing No. 23-MIL-SHOOTER ATTACK-NOA, titled "Product Description/Test Data", sheet 1 of 1, dated 05/19/23, prepared by manufacturer, signed and sealed by Lucas A. Turner, P.E., bearing the Miami-Dade County Product Control Approval stamp with the Notice of Acceptance number and approval date by the Miami-Dade County Product Control Section.

MISSILE IMPACT RATING: None

LIMITATION: This is not a structural approval.

LABELING: Laminated lites under this product approval shall be permanently marked in a corner of the glass with: AOTSF 23 Shooter Attack Film, MDCA, and the laminator's identification mark or code. The interlayer's packaging is to identify the manufacturer's name or logo, manufacturing plant's city and state, model/series, and the statement reading 'Miami-Dade County Product Control Approved.

RENEWAL of this NOA shall be considered after a renewal application has been filed and there has been no change in the applicable building code negatively affecting the performance of this product.

TERMINATION of this NOA will occur after the expiration date or if there has been a revision or change in the materials, use, and/or manufacture of the product or process. Misuse of this NOA as an endorsement of any product, for sales, advertising or any other purposes shall automatically terminate this NOA. Failure to comply with any section of this NOA shall be cause for termination and removal of NOA.

ADVERTISEMENT: The NOA number preceded by the words Miami-Dade County, Florida, and followed by the expiration date may be displayed in advertising literature. If any portion of the NOA is displayed, then it shall be done in its entirety.

INSPECTION: A copy of this entire NOA shall be provided to the user by the manufacturer or its distributors and shall be available for inspection at the job site at the request of the Building Official. This NOA consists of this page 1 and evidence page E-1, as well as approval document mentioned above. The submitted documentation was reviewed by **Manuel Perez, P.E.**



Manuel Perez
8/23/23

NOA No. 23-0803.02
Expiration Date: August 31, 2028
Approval Date: August 31, 2023
Page 1





Armoured One, LLC

NOTICE OF ACCEPTANCE: EVIDENCE SUBMITTED

A. DRAWINGS

1. Manufacturer's original drawings and sections.
(Submitted under NOA No. 23-0803.02)
2. Drawing No. 23-MIL-SHOOTER ATTACK-NOA, titled "Product Description/Test Data", sheet 1 of 1, dated 05/19/23, prepared by manufacturer, signed and sealed by Lucas A. Turner, P.E.
(Submitted under NOA No. 23-0803.02)

B. TESTS

	<u>Test Report No.</u>	<u>Standard</u>	<u>Date</u>	<u>Signature</u>
1.	Intertek-N6813.01-106-18 R0	ASTM C 158	03/30/23	Tanya A. Dolby, P.E.
2.	Intertek-N6813.01-106-18 R0	ASTM D 1929	03/30/23	Tanya A. Dolby, P.E.
3.	Intertek-N6813.01-106-18 R0	ASTM D 2843	03/30/23	Tanya A. Dolby, P.E.
4.	Intertek-N6813.01-106-18 R0	ASTM D 635	03/30/23	Tanya A. Dolby, P.E.

(Submitted under NOA No. 23-0803.02)

C. CALCULATIONS

1. None.

D. QUALITY ASSURANCE

1. Miami-Dade Department of Regulatory and Economic Resources (RER)

E. MATERIAL CERTIFICATIONS

1. None.

F. STATEMENTS

1. Statement letter of conformance, complying with **FBC 7th Edition (2020)** and **FBC 8th Edition (2023)**, dated August 22, 2023, issued by Turner Engineering & Consulting, Inc., signed and sealed by Lucas A. Turner, P.E.
2. Statement letter of no financial interest, dated May 19, 2023, issued by Turner Engineering & Consulting, Inc., signed and sealed by Lucas A. Turner, P.E.

G. OTHERS

1. None.

 Manuel Pérez, P.E.
 Product Control Examiner
 NOA No. 23-0803.02
 Expiration Date: August 31, 2028
 Approval Date: August 31, 2023



ARMoured ONE, LLC, 23-MIL SHOOTER ATTACK FILM

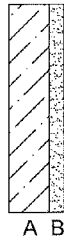

PRODUCT DESCRIPTION:

A. 1/8" THICK MIN. ANNEALED GLASS

B. CLEAR 23-MIL SHOOTER ATTACK FILM, ATTACHED TO INNERMOST SURFACE OF GLASS LITE.

MANUFACTURER:

ARMoured ONE, LLC

MATERIAL PROPERTIES TESTED PER FLORIDA BUILDING CODE:

TEST DESCRIPTION	TEST METHOD	TEST RESULTS
SELF-IGNITION TEMPERATURE	ASTM D 1929	842 F / PASS
FLASH IGNITION TEMPERATURE	ASTM D 1929	752 F / PASS
SMOKE DENSITY RATING	ASTM D 2843	47.2 / PASS
RATE OF BURNING	ASTM D 635	CLASS CC2 / PASS
XENON ARC LAMP WEATHERING	ASTM G 155	NO DAMAGE
AVG. FLEXURAL PROPERTIES	ASTM C 158	CONTROL: 5,185 PSI WEATHERED: 5,500 PSI DIFF. +6.1% / PASS

NOTE:

THIS IS A COMPONENT APPROVAL AND DOES NOT INCLUDE AN EVALUATION OF STRUCTURAL OR BALLISTIC PERFORMANCE OF THIS COMPONENT. SYSTEMS INCORPORATING THIS COMPONENT SHALL APPLY FOR A NOA TO THE MIAMI-DADE COUNTY PRODUCT CONTROL SECTION AND SHALL SUBMIT TEST REPORTS AND OTHER REQUIRED DOCUMENTS SHOWING THAT THE SYSTEM USING THIS COMPONENT WILL RESIST THE LOADS ACCORDING TO CHAPTER 16 OF THE FLORIDA BUILDING CODE.

5/19/2023
 Lucas A. Turner, FL PE #58201
 2428 Old Natchez Trc Trl
 Turner Engineering & Consulting, Inc.
 Camden, TN 38320 | Ph. 941-380-1574

386 N Midler Ave., Syracuse, NY 13206 | Ph. (315) 720-4186

SHEET DESCRIPTION: PRODUCT DESCRIPTION / TEST DATA	DATE DRAWN: 5/19/2023
DRAWING: 23-MIL-SHOOTER-ATTACK-NOA	REV: 0 SHEET: 1 OF 1

Miami Dade County Notice of Acceptance



CLEAR EXPECTATIONS AND ACCEPTABLE GLASS DISTORTIONS IN SECURITY GLASS AND FILM

ARMOURED ONE takes great pride in producing, delivering, and in the case of our security film, installing high-quality products that save lives. To ensure exceptional performance, our glass and film undergoes extreme processes that can cause distortion like bubbles, discolorations, and scratches – occurrences that are experienced industry-wide.

As such, these are not grounds for rejection nor indicative of inferior performance. We adhere to the guidelines established by the American Society for Testing and Materials International (ASTM) on annealed glass, heat-strengthened glass, coated glass, laminated glass, insulated glass units, and filmed glass.

This document includes general guidelines to help you determine if a glass or film related concern is eligible for replacement.

WHAT CAN CAUSE GLASS AND FILM DISTORTION?

Glass and Film Purpose and Function

Necessary processes that are used to create glass products, pressures, glazing, and heat treatments increase strength, safety and/or efficiency. However, they can cause visible distortion.

Glass Assembly Type

Simple monolithic glass being the simplest form of glazing assembly will inherently have the least distortion and fewest blemishes. Laminated glass with multiple panes and the inter layer bonding process and surface applied films will introduce some visual distortion and invites the possibility for blemishes. Combining monolithic glass into multi-pane units, especially utilizing laminated glass in multi-pane units compounds the likelihood of distortion and blemishes in finished products.

Location and Climactic Conditions

Temperature fluctuations, humidity, barometric pressure changes, elevation, seasonal changes, and other environmental factors can also exacerbate the visibility of glass and film distortion.

COMMON BLEMISHES

Linear Blemishes

- Scratch: damage in the form of a line
- Rub: abrasion that produces a frosty appearance
- Dig: A short, but deep scratch

Point/ Spot Blemishes

- Dust/ Contaminant: small particle of foreign material on trapped in glass assembly
- Gaseous Inclusion: small round or elongated bubble
- Pinhole: small area in which glass coating is partially or entirely absent
- Crush: lightly pitted condition with dull appearance

COMMON MANUFACTURING MARKS NOT CONSIDERED BLEMISHES OR GLASS DISTORTION?

Roller Marks: Pattern of waves or ripple marks across glass that occurs during the heating process.

Coloration Differences: Glass exhibiting various coloration or hue differences under various lighting conditions and viewing angles typically resulting from application of thermal (Low-E) coatings, security films, etc.

Label Residue: Residue from label adhesive present on glass from manufacturing, packaging, and handling process.

This residue can be removed with proper cleaning, care, and maintenance.

SPECIFIC CONSIDERATIONS FOR SURFACE APPLIED FILMS

Security Film Curing Time: During installation, our technicians will remove as much of the mounting solution as possible; however, a small amount may remain. This trapped moisture can result in temporary water bubbles or a slightly cloudy appearance. These effects are normal and should be expected, as the cloudiness will gradually dissipate during the curing process.

It is crucial not to pierce water bubbles in an attempt to drain the moisture. Doing so may damage the security film, potentially compromising its effectiveness and voiding the warranty. Please refer to the curing guidelines below for proper care and maintenance.

Climate Conditions & Curing Period: After installation, the security film requires a drying-out period to properly cure. This period can range from several weeks to as long as six (6) months, depending on weather conditions and the location of the filmed glass. Factors such as cold temperatures, rain, snow, overcast skies, and shaded areas (including those with overhangs) may extend the drying-out time, while warm weather and direct sunlight exposure can accelerate the process.

During this phase, it is normal for moisture to be temporarily trapped between the window and the film, potentially creating small moisture bubbles or a slightly cloudy appearance. This is not a defect and should not be a cause for concern—over time, the moisture will evaporate, and the cloudy appearance will clear.

Additionally, the thickness of Armoured One Shooter Attack Film directly impacts the length of the drying-out period as thicker films require more time to fully cure. While the film will steadily improve in performance throughout the process, it will reach its maximum effectiveness approximately 90 days after installation.

Cleaning and Cleaning Solutions: Do not clean the film for thirty (30) days after installation. This will help with the proper curing of the mounting adhesive to the glass.

After the initial 30 day curing period following installation, the windows may be cleaned as you normally would. While most standard commercial and residential glass cleaners are safe for use on security film, one of the most effective cleaning solutions consists of ½ ounce of liquid dish soap mixed with 1 quart of fresh water. This gentle solution helps maintain the clarity and longevity of the film without causing damage.

Cleaning Materials: During installation, some dust particles may cling to the glass or film. To clean your security film surfaces effectively, always use fresh, clean, and soft materials. A soft cloth or clean synthetic sponge is recommended for washing, followed by a clean, soft cloth or a soft rubber squeegee for drying.

To prevent scratches, avoid using bristle brushes, abrasive scrubbing sponges, or any rough cleaning materials. Additionally, do not use cleaning tools that may have been contaminated with dirt particles, as commonly happens when using the same materials for both interior and exterior windows. Proper care will help maintain the integrity and clarity of your security film.

HOW DO I INSPECT MY GLASS?

In order to determine if your glass is eligible for replacement, please inspect it within the industry-wide standard featured below to ensure that every pane is evaluated objectively and



consistently:

- *Inspect glass with the naked eye in the vertical position*
- *View it at a 90-degree angle to the glass*
- *Make all inspections during the daytime in uniform light conditions, but not direct sunlight*
- *Observe from the distance specified by each defect type AND for the noted amount of time*
- *Understand what merits replacement based upon the location of the blemish (central zone, outer zone, glazed zone)*

KEY TERMS

American Society for Testing and Materials International (ASTM): Organization that develops and publishes technical standards for performance criteria for a wide range of materials and products.

Annealed Glass: Raw glass that has not been heat-treated. When broken, it breaks into long dagger-like shards and is very dangerous.

Daylight Opening: Maximum unobstructed visible area of the glazing surface up to the edge of window frame or mullions.

Heat-Strengthened Glass: Glass that is reheated to below melting point and cooled quickly making it nearly two times stronger than annealed glass.

Insulated Glazing Units (IGU): Window assembly of multiple panes separated by an air- or gas-filled space to improve thermal performance and reduce heat transfer.

Laminated Glass: Two or more pieces of glass bonded together with a strong, clear inter layer to provide improved performance for intended use (break resistance, fire resistance, etc.).

Low-E (Emissivity) Glass: Glass with a transparent, metallic oxide coating applied onto a glass surface, typically in IGU assemblies. The coating typically allows short-wave energy to pass through but reflects long-wave infrared energy, which improves the U-value.

Monolithic Glass: Single pane of glass, often produced using the float glass process where molten glass is floated on a bed of molten tin to create a flat, uniform piece of glass.

Safety Glass: Glass that has been toughened, strengthened, or laminated so that it is less likely to splinter when broken. Typically mandated by code and not to be confused with security glass.

Security Film: Transparent, adhesive backed, and anchored plastic layer applied to glass surfaces to enhance its strength and resistance to shattering. It's designed to hold broken glass together in the event of impact, preventing injuries and deterring forced entry.

Tempered Glass: Glass that is reheated to below melting point and cooled twice as fast as heat-strengthened glass making it nearly four times stronger than annealed glass. When shattered, it breaks into small pieces making it far less dangerous.

APPLICABLE INDUSTRY REFERENCED STANDARDS

Please refer to www.astm.org for access to the complete library of ASTM standards if needed. Below are the pertinent standards applicable to security glass and film performance

ASTM C1036 Standard Specification for Flat Glass: This is the standard that establishes all inspection and allowable distortion and blemish criteria for glass and glass related assemblies primarily used in architectural glazing.

ASTM F3561 Standard Test Method for Forced-Entry-Resistance of Fenestration Systems After Simulated Active Shooter Attack: While this standard does not address aesthetic characteristics of the glass and film, it outlines protection performance requirements from an active shooter situation that in order to be achieved, creates the visual imperfections deemed allowable by ASTM C1036.

INSPECTION PROCEDURE

While every reasonable effort is employed to prevent and avoid manufacturing and installation imperfections, when using laminated security glass and surface-applied films, it is important to recognize that minor imperfections in the final installation are inevitable. Unlike standard glass, which prioritizes aesthetics, security glass and film products are designed primarily as a barrier against forced-entry. Security glass and films share similarities with fire-rated glazing and laminated glass, where slight imperfections and distortions are expected.

Unlike standard aesthetic inspection procedures used for architectural flat glass, the evaluation of filmed and security glass employs a similar, but different approach. Due to the unique application processes involved, these materials cannot be assessed with the same level of perfection. The layering, adhesives, and security enhancements inherent in these systems may introduce minor variations that do not compromise their performance but distinguish them from traditional glass. As such, inspection criteria must account for these characteristics while ensuring the integrity and effectiveness of the installation.

VIEWING DISTANCES AND TIMES FOR GLAZING BLEMISHES

Where you stand and how long you review a potential blemish will help you determine if your glass pane is eligible for replacement. See Table 1 for viewing distance guidelines.

Blemishes in the glass or film not visible from the inspection position are allowable. Allowable blemishes do not affect the glass or film performance.

There could be distortion or a champaign effect from certain angles within all zones. This is typical in security or fire rated glass films and glass and is unavoidable.

ACCEPTABLE IMPERFECTIONS

Blemishes are eligible for replacement based upon their location on the glass pane. Before you examine your glass,

TABLE 1: Viewing Distances and Times for Glazing Blemishes						
Blemish Type	Viewing Distance (Based on Size of Glass Pane)			Viewing Time (Based on Size of Glass Pane)		
	6 Square Feet or Less	6-25 Square Feet	Over 25 Square Feet	6 Square Feet or Less	6-25 Square Feet	Over 25 Square Feet
Linear	6 Feet Away		10 Feet Away	5 Seconds	10 Seconds	20 Seconds
Point	39 Inches Away			5 Seconds	10 Seconds	20 Seconds





it is important to understand the various viewing areas for each pane/unit: central zone, outer zone, and glazed zone.

- The **CENTRAL ZONE** is a rectangle in the center of the lite whose width and height are 50% of the overall pane size.
- The **OUTER ZONE** extends from the outside perimeter edge of the central zone to the glazed zone.
- The **GLAZED ZONE** extends from the glass edge to 11/16" from the edge of the lite.

See Tables 2 and 3 below for observation and inspection procedures for linear and point blemishes, respectively.

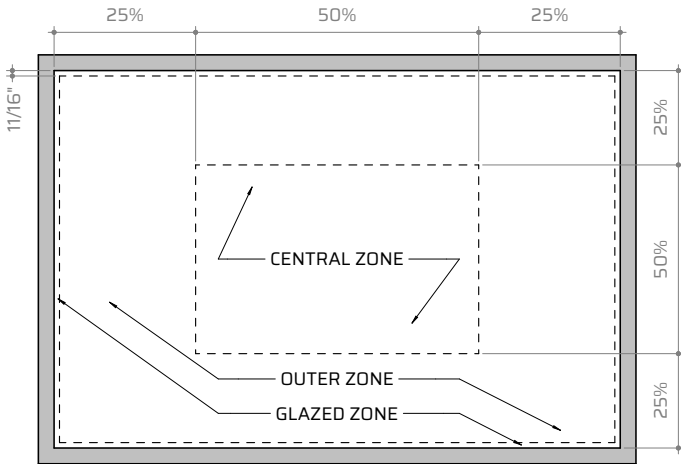

OWNER ACKNOWLEDGEMENT

Owner: _____
 Project Name/ Location: _____
 Street Address: _____
 City: _____ State: _____ Zip: _____
 Phone: _____ Ext. _____
 Email: _____

Owner Signature: _____

IMPORTANT SECURITY CONSIDERATIONS

Shooter/Attack Certified Security Film and Glass: Armoured One Shooter/Attack security glass and film products are "shooter/attack certified" but not bullet-resistant or bulletproof. While it significantly strengthens glass and slows intrusion, a determined attacker with enough time and effort may still penetrate it. Security film is designed to delay and deter intruders, providing critical time for emergency response. However, we cannot guarantee that entry will be entirely prevented and for your safety, never stand behind laminated or filmed glass while it is being shot.

Comprehensive Plan | Other Ways to Stay Protected: Security film and glass should be just considered just one component of a comprehensive security plan. We strongly recommend implementing additional security measures including, but not limited to, surveillance cameras, AI weapons detection, alarms, emergency response plans, and active intruder training. While security film provides a crucial barrier slowing intruders, with enough time and effort, it may eventually be breached.

TABLE 2: Linear Blemish Inspection Procedure

Viewing Area	Blemish Intensity	Replacement Eligibility
Glazing Zone	Light and Heavy	Any occurrence is not eligible for replacement
Outer Zone	Light	Any occurrence greater than 3-inches is eligible for replacement
	Heavy	Multiple occurrences less than 3-inches with a separation less than 24-inches is eligible for replacement
Central Zone	Light	Any occurrence greater than 3-inches is eligible for replacement
	Medium to Heavy	Multiple occurrences less than 3-inches, but at least 2-inches with a separation less than 24-inches is eligible for replacement

TABLE 3: Point Blemish Inspection Procedure

Size of Glass Pane	Blemish Intensity		Replacement Eligibility	
	Glazing and Outer Zone	Central Zone	Glazing and Outer Zone	Central Zone
25 Square Feet or Less	3/32-inch or less	1/16-inch or less	Any pane with a point blemish larger than 3/32-inch is eligible for replacement.	Any pane with a point blemish larger than 1/16-inch is eligible for replacement.
25-75 Square Feet	3/16-inch or less	1/8-inch or less	Any pane with a point blemish larger than 3/16-inch is eligible for replacement.	Any pane with a point blemish larger than 1/8-inch is eligible for replacement.
Over 75 Square Feet	1/4-inch or less		Any pane with a point blemish larger than 1/4-inch is eligible for replacement.	





PRODUCT WARRANTY STATEMENT

Armoured One LLC (AO) warrants the 23MIL Security window film sold and professionally installed to the interior side of glass by AO Licensed Installer (Installer) against cracking, changing color, crazing, delaminating, demetallizing, and adhesive failure.

AO's warranty extends for a period of fifteen (15) years from the date of **installation completion**. This Limited Warranty covers only window films approved by the manufacturer for flat glass applications, according to the most current Film to Glass Application Chart at the time of installation.

Recommendations by the manufacturer, verbal or in writing, are not to be considered confirmation of coverage by this warranty certificate. In the event of film failure, AO will replace the film, (or issue credit for the film). Any labor cost or credits will need prior written approval from AO.

THE TERMS AND CONDITIONS OF THIS LIMITED COVERAGE ARE AS FOLLOWS:

1. Coverage is limited to the original owner of the property at the time of installation. Subject to registration of original warranty document signed by the Installer.
2. In no event shall AO be liable or responsible for loss and or damage, direct, incidental, or consequential, except as expressly set forth herein. This Limited Warranty is made in lieu of all warranties, expressed or implied, and is void if the product has been subject to abuse or improper care. This Warranty gives the purchaser specific legal rights, and the purchaser may have other rights that vary. AO reserves the right to inspect the damaged film/ window before replacement. Fraud by the Installer or customer shall void this Limited Warranty.
3. This Limited Warranty shall not apply, and shall not be enforceable, when:
 - A. Installer's practices do not conform to Armoured One's published installation policies and procedures.
 - B. Cleaning and maintenance of film is not in accordance with manufacturer's instructions.
 - C. Two or more films are applied to the same glass surface.
 - D. Filmed windows are triple or more pane construction, textured, wire film glass, or an IG unit inclusive of a suspended film.
 - E. Film is applied to any glass on which there is paint, lettering, signs, stickers or other permanent or temporary ornamentation.
 - F. Filmed glass has prior damage, is chipped, cracked, has holes in it, or light is visible between the frame and the glass.
 - G. The film is applied to plastics, acrylics, polycarbonates or other non-glass substrates (if not specifically permissible by AO).
 - H. One glass side dimension is greater than eleven (11) feet (3.5m) and/or the surface of double pane glass has more than forty (40) square feet (3.7 m2) surface area.
 - I. Film applied at an altitude above sea level greater than 7,000ft (2133m) requires prior written approval

from AO.

- J. Film applied to interior of skylights requires prior written approval from AO.
- K. Clear annealed glass is thicker than 3/8-inch (9.5mm), or tinted annealed glass is thicker than 1/4-inch (6mm).
- L. Film that is only partially applied to glass.
- M. Windows are architecturally odd-shaped, larger than twenty (20) square feet (1.8m²).
- N. Film applied to any type of laminated glass requires prior written approval from AO.
- O. Damage caused by acts of nature (accidents, floods, fire, explosion etc.).
- P. Film that is applied to glass block.

This Limited warranty is valid only if the manufacturer's original copy is executed, received, validated, and registered by the AO Warranty Department within sixty (60) days from the completion of the installation. This form must be signed by both the Owner/ customer and the Installer.

Owner: _____

Project Name/ Location: _____

Street Address: _____

City: _____ State: _____ Zip: _____

Phone: _____ Ext. _____

Email: _____

Owner Signature: _____

AO Project Manager: _____

Purchase Order Number: _____

Warranty Start Date: _____

AO Signature: _____

Please return completed warranty to filmwarranty@armouredone.com.



Armoured One's 23 mil shooter attack film is fully compatible with glass manufacturers like Vitro, Pilkington, Oldcastle, and others. Since our non-thermal, clear film doesn't absorb heat or cause stress, it avoids the risks typically excluded by glass manufacturer warranties.

If our film directly causes any issues, Armoured One is prepared to cover the manufacturer's warranty. This reflects our confidence in the product and commitment to maintaining the integrity of your glass.



Brooksville Elementary School 44

Central High School..... 51

Chocachatti Elementary School..... 56

Deltona Elementary School..... 61

DS Parrott Middle School 70

Endeavor Academy..... 75

Explorer K-8 School 79

FW Springstead High School 88

Fox Chapel Middle School 95

Hernando High School..... 105

JD Floyd Elementary School 112

Moton Elementary School 117

Pine Grove Elementary School..... 123

Powell Middle School..... 129

Springhill Elementary School..... 134

Suncoast Elementary School 141

Weeki Wachee High School..... 147

West Hernando Middle School 155

Westside Elementary School 161

Winding Water K-8 School 167

BROOKSVILLE ELEMENTARY SCHOOL

Tim Czyz

Friday, May 1, 2026

Prepared For Hernando District Schools

10 Issues Identified



ISSUE 1

Assigned To Cafeteria Entrance

Door 4@ 24 1/2x 69

SL 4@ 16 3/8x 40 3/4

SL 4@ 16 3/8x 39 3/8-b

Film removal on side lights

Both ends of serving line hallway



ISSUE 2

Assigned To Cafeteria Entrance



ISSUE 3

Assigned To Library

Door 2@ 24 1/4x 70 1/4

SL 4@ 27 3/4x 35



ISSUE 4

Assigned To Library Back Doors

Door 2@ 24 1/4x 70 1/4



ISSUE 5

Assigned To Building Four Hallway Doors

Door 4@ 24 1/4x 70 1/4

SL 12@ 7 3/4x 26



ISSUE 6

Assigned To Building Two Hallway Doors

Door 4@ 24 1/4x 70 1/4

SL 12@ 24x 26

Film removal on sidelights



ISSUE 7

Assigned To Building Two Blue Hallway Doors

Door 4@ 24 1/4x 70 1/4

Film removal



ISSUE 8

Assigned To Building Two Red Hallway Doors

Door 4@ 24 1/4x 70 1/4

Film removal



ISSUE 9

Assigned To Building Three Hallway Doors

Door 4@ 24 1/4x 70 1/4

SL 12@ 15 5/8x 26



ISSUE 10

Assigned To Building Five

Door 2@ 24 1/4x 70 1/4

SL 3@ 18x 26

Armoured One LLC
 386 North Midler Ave.
 Syracuse, NY 13206 US
 +1 3157204186
 ar@armouredone.com
 www.armouredone.com



Quote#: Q-04114

ADDRESS	SHIP TO
Hernando County School District 919 North Broad Street Brooksville FL 34601	Hernando County School District 919 North Broad Street Brooksville FL 34601

Date Provided:

Expires On: 6/30/2026

Purchase Order:

SHIP VIA	Payment Terms	ESTIMATOR	JOB NAME
	Net 30	Joshua Dorschner	Brooksville Elementary School

ACTIVITY	QTY	PRICE	AMOUNT
Film Installation: AOTSF23 SECURITY FILM Building 3 Hallway - Door : 24 1/4 X 70 1/4	4	\$546.80	\$2,187.20
Film Installation: AOTSF23 SECURITY FILM Building 3 Hallway - SL : 15 5/8 X 26	12	\$138.66	\$1,663.92
Film Installation: AOTSF23 SECURITY FILM Building 4 Hllwy - Door : 24 1/4 X 70 1/4	4	\$546.80	\$2,187.20
Film Installation: AOTSF23 SECURITY FILM Building 4 Hllwy - SL : 7 3/4 X 26	12	\$138.66	\$1,663.92
Film Installation: AOTSF23 SECURITY FILM Cafe Ent - Door : 24 1/2 X 69	4	\$542.60	\$2,170.40
Film Installation: AOTSF23 SECURITY FILM Cafe Ent - SL : 16 3/8 X 40 3/4	4	\$214.18	\$856.72
Film Installation: AOTSF23 SECURITY FILM Cafe Ent - SL : 16 3/8 X 39 3/8	4	\$206.95	\$827.80
Film Installation: AOTSF23 SECURITY FILM Library - Door : 24 1/4 X 70 1/4	2	\$546.80	\$1,093.60
Film Installation: AOTSF23 SECURITY FILM Library - SL : 27 3/4 X 35	4	\$311.74	\$1,246.96
Film Installation: AOTSF23 SECURITY FILM Library Back - Door : 24 1/4 X 70 1/4	2	\$546.80	\$1,093.60

ACTIVITY	QTY	PRICE	AMOUNT
Film Installation: AOTSF23 SECURITY FILM Building 2 Hallway - Door : 24 1/4 X 70 1/4	4	\$546.80	\$2,187.20
Film Installation: AOTSF23 SECURITY FILM Building 2 Hallway - SL : 24 X 26	12	\$200.29	\$2,403.48
Film Installation: AOTSF23 SECURITY FILM Building 2 Blue Hallway - Door : 24 1/4 X 70 1/4	4	\$546.80	\$2,187.20
Film Installation: AOTSF23 SECURITY FILM Building 2 Red Hallway - Door : 24 1/4 X 70 1/4	4	\$546.80	\$2,187.20
Film Installation: AOTSF23 SECURITY FILM Building 5 - Door : 24 1/4 X 70 1/4	2	\$546.80	\$1,093.60
Film Installation: AOTSF23 SECURITY FILM Building 5 - SL : 18 X 26	3	\$150.22	\$450.66
Freight	1	\$600.00	\$600.00
Crate	1	\$200.00	\$200.00
Mobility Fee	1	\$2,600.00	\$2,600.00
TOTAL:			\$28,900.66

Total Pieces
81.00

Total Square Feet
530.37

Terms & Conditions

Terms: 60% down to do final measure, fabricate product, and deliver on-site. Balance due upon completion of installation.

Includes all products, installation, and prevailing wage.

** Wood stops are not acceptable for the proper function of Shooter/Attack Certified Security film and may require upgraded vision kits.

***installation on glass blocks is not allowed.

Disclaimer: Armoured One's 23 MIL Shooter Attack Film is not "bullet-proof" or "bullet-resistant". It is designed to slow down an attacker with a gun.

Accepted By:

Accepted Date:

____/____/____

Approved as to Legal Sufficiency

Caroline I. Mockler, Esq.
Staff Counsel, HCSD

5:46 pm, 05/14/2026

CENTRAL HIGH SCHOOL

Tim Czyz

Tuesday, April 28, 2026

Prepared For Hernando District Schools

4 Issues Identified



ISSUE 1

Assigned To Building Six Parking Lot Side

2@52 1/8x 52 1/8-these two windows need a waiver, no anchoring in corner

1@ 92 1/2x 52 1/4

6@ 49 3/8x 52 1/4

1@ 92 1/2x 52 1/4

3@ 49 3/8x 52 1/4

1@ 47 1/4x 52 1/4- this Pease needs waiver no anchoring in corner

Measurements go from left to right from outside



ISSUE 2

Assigned To Building One Parking Lot Side

2@ 49 1/2x 52 1/2

1@ 48 1/2x 52 1/8

1@ 46 1/2x 52 1/8

1@ 48 1/3x 52 1/8

2@ 48 1/2x 52 1/8- outsides of this set

1@ 46 3/8x 52 1/8- m

2@ 49 3/8x 52 1/8

Measurements go from left to right from the outside



ISSUE 3

Assigned To Building One Right Side Entrance Parking Lot Side

SL 1@ 30 1/2x 52 1/8



ISSUE 4

Assigned To Building One Field House Side

1 @ 92 3/8x 52 3/8

Armoured One LLC
 386 North Midler Ave.
 Syracuse, NY 13206 US
 +1 3157204186
 ar@armouredone.com
 www.armouredone.com



Quote#: Q-04141

ADDRESS

Hernando County School District
 919 North Broad Street
 Brooksville
 FL
 34601

SHIP TO

Hernando County School District
 919 North Broad Street
 Brooksville
 FL
 34601

Date Provided:

Expires On: 6/30/2026

Purchase Order:

SHIP VIA

Payment Terms
 Net 30

ESTIMATOR
 Joshua Dorschner

JOB NAME
 Central High School

ACTIVITY	QTY	PRICE	AMOUNT
Film Installation: AOTSF23 SECURITY FILM Building One Right Side Entrance Parking Lot Side - SL : 30 1/2 X 52 1/8	1	\$668.60	\$668.60
Freight - Included on Q4115	1	\$0.00	\$0.00
Crate - Included on Q4115	1	\$0.00	\$0.00
Mobility Fee - Included on Q4115	1	\$0.00	\$0.00
TOTAL:			\$668.60

Total Pieces
 1.00

Total Square Feet
 11.04

Terms & Conditions

Terms: 60% down to do final measure, fabricate product, and deliver on-site. Balance due upon completion of installation.

Includes all products, installation, and prevailing wage.

** Wood stops are not acceptable for the proper function of Shooter/Attack Certified Security film and may require upgraded vision kits.

IMPORTANT: A finance charge of 1.5% per month (18% per annum) will be charged on past due balances.

***installation on glass blocks is not allowed.

Disclaimer: Armoured One's 23 MIL Shooter Attack Film is not "bullet-proof" or "bullet-resistant". It is designed to slow down an attacker with a gun.

Accepted By: _____

Accepted Date: ____/____/____

Approved as to Legal Sufficiency
Caroline I. Mockler, Esq.
Staff Counsel, HCSD
5:46 pm, 05/14/2026

CHOCACHATTI ELEMENTARY SCHOOL

Tim Czyz

Friday, May 1, 2026

Prepared For Hernando District Schools

7 Issues Identified



ISSUE 1

Assigned To Exterior Entrance But 4 Kinder Building Four

Door 2@ 24 1/2x 33

Door 2@ 24 1/2x 25 1/4

SL 1@ 15 1/8x 50

SL 1@ 15 1/8x 30

This issue slightly exposed to the weather



ISSUE 2

Assigned To Entrance By 3029 Music Lab

Door 2@ 24 1/2x 33

Door 2@ 24 1/2x 25 1/4

SL 1@ 43x 50

SL 1@ 43x 30

This issue is fully exposed to sunlight and weather



ISSUE 3

Assigned To Cafeteria

Door 2@ 23 5/8x 31 3/4

Door 2@ 23 5/8x 25 7/8

SL 2@ 36 3/8x 48 1/2

SL 2@ 36 3/8x 28 3/8

SL 1@ 14 1/2x 48 1/2

SL 1@ 14 1/2x 28 3/8

Tint removal



ISSUE 4

Assigned To Cafeteria

Door 6@ 23 1/2x 31 3/4

Door 6@ 23 1/2x 25 7/8

SL 3@ 14 1/2x 48 1/2

SL 3@ 14 1/2x 28 3/8

Tint removal



ISSUE 5

Assigned To Entrance By 2008 Art Lab

Door 2@ 24 1/2x 33

Door 2@ 24 1/2x 25 1/4

SL 1@ 14 3/4x 50

SL 1@ 14 3/4x 30



ISSUE 6

Assigned To Entrance By Admin One

Door 2@ 24 1/2x 33

Door 2@ 24 1/2x 25 1/4

SL 1@ 14 3/4x 50

SL 1@ 14 3/4x 29 7/8

This issue is slightly open to the weather



ISSUE 7

Assigned To Entrance Bay 612 Classroom

Door 2@ 26 1/8x 71 3/8

SL 1@ 13 1/4x 49 1/4

SL 1@ 13 1/4x 28 3/4

Armoured One LLC
 386 North Midler Ave.
 Syracuse, NY 13206 US
 +1 3157204186
 ar@armouredone.com
 www.armouredone.com



Quote#: Q-04117

ADDRESS	SHIP TO
Hernando County School District 919 North Broad Street Brooksville FL 34601	Hernando County School District 919 North Broad Street Brooksville FL 34601

Date Provided:

Expires On: 6/30/2026

Purchase Order:

SHIP VIA	Payment Terms	ESTIMATOR	JOB NAME
	Net 30	Joshua Dorschner	Chocachatti Elementary School

ACTIVITY	QTY	PRICE	AMOUNT
Film Installation: AOTSF23 SECURITY FILM Ent By Admin One - Door : 24 1/2 X 33	2	\$261.81	\$523.62
Film Installation: AOTSF23 SECURITY FILM Ent By Admin One - Door : 24 1/2 X 25 1/4	2	\$200.32	\$400.64
Film Installation: AOTSF23 SECURITY FILM Ent By Admin One - SL : 14 3/4 X 50	1	\$238.82	\$238.82
Film Installation: AOTSF23 SECURITY FILM Ent By Admin One - SL : 14 3/4 X 30	1	\$143.29	\$143.29
Film Installation: AOTSF23 SECURITY FILM Ent Bay 612 Classroom - Door : 26 1/8 X 71 3/8	2	\$603.82	\$1,207.64
Film Installation: AOTSF23 SECURITY FILM Ent Bay 612 Classroom - SL : 13 1/4 X 49 1/4	1	\$211.31	\$211.31
Film Installation: AOTSF23 SECURITY FILM Ent Bay 612 Classroom - SL : 13 1/4 X 28 3/4	1	\$139.89	\$139.89
Freight	1	\$600.00	\$600.00
Crate	1	\$200.00	\$200.00
Mobility Fee	1	\$800.00	\$800.00
TOTAL:			\$4,465.21

IMPORTANT: A finance charge of 1.5% per month (18% per annum) will be charged on past due balances.

Total Pieces
10.00

Total Square Feet
61.09

Terms & Conditions

Terms: 60% down to do final measure, fabricate product, and deliver on-site. Balance due upon completion of installation.

Includes all products, installation, and prevailing wage.

** Wood stops are not acceptable for the proper function of Shooter/Attack Certified Security film and may require upgraded vision kits.

***installation on glass blocks is not allowed.

Disclaimer: Armoured One's 23 MIL Shooter Attack Film is not "bullet-proof" or "bullet-resistant". It is designed to slow down an attacker with a gun.

Accepted By: _____

Accepted Date: ____/____/____

Approved as to Legal Sufficiency

Caroline I. Mockler, Esq.
Staff Counsel, HCSD

5:46 pm, 05/14/2026

DELTONA ELEMENTARY SCHOOL

Tim Czyz

Wednesday, April 29, 2026

Prepared For Hernando District Schools

18 Issues Identified



ISSUE 1

Assigned To Main Entrance To Enter Campus

Door 4@ 24 1/4x 67 1/4

SL 2@ 11 1/4x 56 1/2

SL 2@ 11 1/4x 26 1/4

Windows 4@ 40 1/2x 56 1/2

Windows 4@ 40 1/2x 26 1/4

Center windows are exposed to direct weather and sunlight, and the rest of it is somewhat exposed to direct sunlight

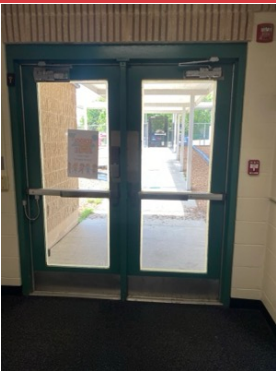

ISSUE 2

Assigned To Ent By Rm 212

Door 2@ 24 1/8x 67 3/8

Tint removal



ISSUE 3

Assigned To Entrance By Room 309

Door 2@ 24 1/4x 67 1/4

Tint removal



ISSUE 4

Assigned To Ent 341

Door 2@ 24 1/4x 67 1/4



ISSUE 5

Assigned To Entrance By 519 Restroom Off Café
Door 2@ 24 1/4x 67 1/8



ISSUE 6

Assigned To Cafeteria
Door 2@ 24 1/4x 67 1/4
Tint removal



ISSUE 7

Assigned To Entrance By 400 Wing
Door 2@ 24 1/4x 67 3/8



ISSUE 8

Assigned To Rm 501
Door 1@ 24 1/4x 67 3/8



ISSUE 9

Assigned To Ent By Rm 407

Door 2 @ 24 1/4x 67 3/8

Tint removal



ISSUE 10

Assigned To Technology Center By Room 423

Door 1 @ 24 1/4x 67 3/8

Tint removal



ISSUE 11

Assigned To Ent By Rm 602

Door 2 @ 24 1/4x 67 1/4

Tint removal

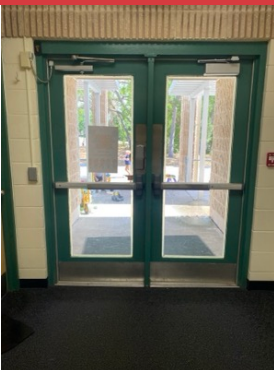

ISSUE 12

Assigned To Ent By Rm 625

Door 2 @ 24 1/4x 67 3/8

Tint removal



ISSUE 13

Assigned To Computer Lab 4-427

Door 1 @ 24 1/4x 67 3/8

Tint removal



ISSUE 14

Assigned To Library

Door 4 @ 6 1/2x 30 1/2

Take apart, clip type



ISSUE 15

Assigned To Library

Windows 8 @ 30 3/8x 62 3/4



ISSUE 16

Assigned To Building 10 Hallway Doors

4 @ 6 1/2x 30 1/2

Take apart, clip type



ISSUE 17

Assigned To Building 10–100 Stair

Door 1 @ 3 1/2x 30 1/2

Take apart, clip type



ISSUE 18

Assigned To Building 10–113 Stair

Door 1 @ 3 1/2x 30 1/2

Take apart, clip tape

Armoured One LLC
 386 North Midler Ave.
 Syracuse, NY 13206 US
 +1 3157204186
 ar@armouredone.com
 www.armouredone.com



Quote#: Q-04147

ADDRESS	SHIP TO
Hernando County School District 919 North Broad Street Brooksville FL 34601	Hernando County School District 919 North Broad Street Brooksville FL 34601

Date Provided:

Expires On: 6/30/2026

Purchase Order:

SHIP VIA	Payment Terms	ESTIMATOR	JOB NAME
	Net 30	Joshua Dorschner	Deltona Elementary School

ACTIVITY	QTY	PRICE	AMOUNT
Film Installation: AOTSF23 SECURITY FILM Ent By 519 Restroom off Cafe - Door : 24 1/4 X 67 1/8	2	\$523.83	\$1,047.66
Film Installation: AOTSF23 SECURITY FILM Ent By Rm 212 - Door : 24 1/8 X 67 3/8	2	\$523.07	\$1,046.14
Film Installation: AOTSF23 SECURITY FILM Ent By Rm 309 - Door : 24 1/4 X 67 1/4	2	\$524.80	\$1,049.60
Film Installation: AOTSF23 SECURITY FILM Ent 341 - Door : 24 1/4 X 67 1/4	2	\$524.80	\$1,049.60
Film Installation: AOTSF23 SECURITY FILM Cafe - Door : 24 1/4 X 67 1/4	2	\$524.80	\$1,049.60
Film Installation: AOTSF23 SECURITY FILM Ent By 400 Wing - Door : 24 1/4 X 67 3/8	2	\$525.78	\$1,051.56
Film Installation: AOTSF23 SECURITY FILM Rm 501 - Door : 24 1/4 X 67 3/8	1	\$525.78	\$525.78
Film Installation: AOTSF23 SECURITY FILM Ent By Rm 407 - Door : 24 1/4 X 67 3/8	2	\$525.78	\$1,051.56
Film Installation: AOTSF23 SECURITY FILM Tech Ctr By Rm 423 - Door : 24 1/4 X 67 3/8	1	\$525.78	\$525.78
Film Installation: AOTSF23 SECURITY FILM Ent By Rm 602 - Door : 24 1/4 X 67 1/4	2	\$524.80	\$1,049.60

IMPORTANT: A finance charge of 1.5% per month (18% per annum) will be charged on past due balances.

ACTIVITY	QTY	PRICE	AMOUNT
Film Installation: AOTSF23 SECURITY FILM Library - Door : 6 1/2 X 30 1/2	4	\$139.02	\$556.08
Film Installation: AOTSF23 SECURITY FILM Ent By Rm 625 - Door : 24 1/4 X 67 3/8	2	\$525.78	\$1,051.56
Film Installation: AOTSF23 SECURITY FILM Comp Lab 4-427 - Door : 24 1/4 X 67 3/8	1	\$525.78	\$525.78
Film Installation: AOTSF23 SECURITY FILM Bldg 10 Hllway - Door : 6 1/2 X 30 1/2	4	\$139.02	\$556.08
Film Installation: AOTSF23 SECURITY FILM Bldg 10-100 Stair - Door : 3 1/2 X 30 1/2	1	\$139.02	\$139.02
Film Installation: AOTSF23 SECURITY FILM Building 10-113 Stair - Door : 3 1/2 X 30 1/2	1	\$139.02	\$139.02
Freight	1	\$600.00	\$600.00
Crate	1	\$200.00	\$200.00
Mobility Fee	1	\$1,500.00	\$1,500.00
TOTAL:			\$14,714.42

Total Pieces
31.00

Total Square Feet
244.89

Terms & Conditions

Terms: 60% down to do final measure, fabricate product, and deliver on-site. Balance due upon completion of installation.

Includes all products, installation, and prevailing wage.

** Wood stops are not acceptable for the proper function of Shooter/Attack Certified Security film and may require upgraded vision kits.

***installation on glass blocks is not allowed.

Disclaimer: Armoured One's 23 MIL Shooter Attack Film is not "bullet-proof" or "bullet-resistant". It is designed to slow down an attacker with a gun.

Approved as to Legal Sufficiency

Caroline I. Mockler, Esq.
Staff Counsel, HCSD

5:45 pm, 05/14/2026

Accepted By: _____

Accepted Date: ____/____/____

IMPORTANT: A finance charge of 1.5% per month (18% per annum) will be charged on past due balances.

DS PARROT MIDDLE SCHOOL

Tim Czyz

Monday, May 4, 2026

Prepared For Hernando District Schools

8 Issues Identified



ISSUE 1

Assigned To Hallway 200 Doors

Door 4 @ 5 1/2x 20 1/2

Take apart clip type



ISSUE 2

Assigned To Gymnasium Doors

Door 4 @ 24 1/2x 69

SL 1 @ 36 1/2x 82



ISSUE 3

Assigned To Is It Going Back Door?

Door 1 @ 6x 20 3/4

Take apart, heavy paint



ISSUE 4

Assigned To Music Wing Courtyard Entrance

Door 2 @ 7x 30 3/4

Take apart, heavy paint

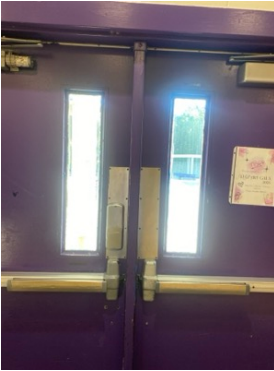

ISSUE 5

Assigned To Café

Door 6@ 7x 31 1/4

Check apart, very heavy pain



ISSUE 6

Assigned To 100 Hallway Doors

Door 10@ 5 1/2x 20 5/8- take apart clip tape



ISSUE 7

Assigned To 124 Admin Storage

Door 1@ 6 1/4x 21

Take apart

ISSUE 8

Armoured One LLC
 386 North Midler Ave.
 Syracuse, NY 13206 US
 +1 3157204186
 ar@armouredone.com
 www.armouredone.com



Quote#: Q-04118

ADDRESS	SHIP TO
Hernando County School District 919 North Broad Street Brooksville FL 34601	Hernando County School District 919 North Broad Street Brooksville FL 34601

Date Provided:

Expires On: 6/30/2026

Purchase Order:

SHIP VIA	Payment Terms	ESTIMATOR	JOB NAME
	Net 30	Joshua Dorschner	DS Parrot Middle School

ACTIVITY	QTY	PRICE	AMOUNT
Film Installation: AOTSF23 SECURITY FILM Hallway 200 - Door : 5 1/2 X 20 1/2	4	\$138.18	\$552.72
Film Installation: AOTSF23 SECURITY FILM Gym - Door : 24 1/2 X 69	4	\$540.73	\$2,162.92
Film Installation: AOTSF23 SECURITY FILM Gym - SL : 36 1/2 X 82	1	\$957.34	\$957.34
Film Installation: AOTSF23 SECURITY FILM Is it Going Back - Door : 6 X 20 3/4	1	\$138.18	\$138.18
Film Installation: AOTSF23 SECURITY FILM Music Wing Courtyard Ent - Door : 7 X 30 3/4	2	\$138.18	\$276.36
Film Installation: AOTSF23 SECURITY FILM Cafe - Door : 7 X 31 1/4	6	\$138.18	\$829.08
Film Installation: AOTSF23 SECURITY FILM Hallway - Door : 5 1/2 X 20 5/8	10	\$138.18	\$1,381.80
Film Installation: AOTSF23 SECURITY FILM 124 Admin Storage - Door : 6 1/4 X 21	1	\$138.18	\$138.18
Freight	1	\$600.00	\$600.00
Crate	1	\$200.00	\$200.00
Mobility Fee	1	\$800.00	\$800.00
TOTAL:			\$8,036.58

IMPORTANT: A finance charge of 1.5% per month (18% per annum) will be charged on past due balances.

Total Pieces
29.00

Total Square Feet
92.63

Terms & Conditions

Terms: 60% down to do final measure, fabricate product, and deliver on-site. Balance due upon completion of installation.

Includes all products, installation, and prevailing wage.

** Wood stops are not acceptable for the proper function of Shooter/Attack Certified Security film and may require upgraded vision kits.

***installation on glass blocks is not allowed.

Disclaimer: Armoured One's 23 MIL Shooter Attack Film is not "bullet-proof" or "bullet-resistant". It is designed to slow down an attacker with a gun.

Accepted By: _____

Accepted Date: ____/____/____

Approved as to Legal Sufficiency

Caroline I. Mockler, Esq.
Staff Counsel, HCSD

5:45 pm, 05/14/2026

ENDEAVOR SCHOOL

Tim Czyz

Tuesday, April 28, 2026

Prepared For Hernando District Schools

4 Issues Identified



ISSUE 1

Assigned To Main Ent

Door 2@ 9x 33 3/4- take apart

This is replacement armored one film, so looks terrible



ISSUE 2

Assigned To Shush Floor Parking Lot Side

32@ 19 1/4x 55 5/8



ISSUE 3

Assigned To Cafe

Door 2@ 9x 34 take apart

Windows 8@ 19 1/8x 55 3/4

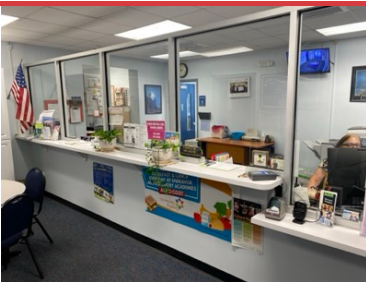

ISSUE 4

Assigned To Main Office Reception Glass

4@ 44 1/8x 44 3/8

1@ 27 1/2x 54 1/4

Pass through will be cut on site.

Armoured One LLC
 386 North Midler Ave.
 Syracuse, NY 13206 US
 +1 3157204186
 ar@armouredone.com
 www.armouredone.com



Quote#: Q-04144

ADDRESS	SHIP TO
Hernando County School District 919 North Broad Street Brooksville FL 34601	Hernando County School District 919 North Broad Street Brooksville FL 34601

Date Provided:

Expires On: 6/30/2026

Purchase Order:

SHIP VIA	Payment Terms	ESTIMATOR	JOB NAME
	Net 30	Joshua Dorschner	Endeavor Academy

ACTIVITY	QTY	PRICE	AMOUNT
Film Installation: AOTSF23 SECURITY FILM Cafe - Door : 9 X 34	2	\$138.21	\$276.42
Film Installation: AOTSF23 SECURITY FILM Main Office Reception Glass - Window : 44 1/8 X 44 3/8	4	\$626.44	\$2,505.76
Film Installation: AOTSF23 SECURITY FILM Main Office Reception Glass - Window : 27 1/2 X 54 1/4	1	\$477.30	\$477.30
Freight	1	\$600.00	\$600.00
Crate	1	\$200.00	\$200.00
Mobility Fee	1	\$800.00	\$800.00
TOTAL:			\$4,859.48

Total Pieces	Total Square Feet
7.00	69.00

Terms & Conditions

Terms: 60% down to do final measure, fabricate product, and

IMPORTANT: A finance charge of 1.5% per month (18% per annum) will be charged on past due balances.

deliver on-site. Balance due upon completion of installation.

Includes all products, installation, and prevailing wage.

** Wood stops are not acceptable for the proper function of Shooter/Attack Certified Security film and may require upgraded vision kits.

***installation on glass blocks is not allowed.

Disclaimer: Armoured One's 23 MIL Shooter Attack Film is not "bullet-proof" or "bullet-resistant". It is designed to slow down an attacker with a gun.

Accepted By: _____

Accepted Date: ____/____/____

Approved as to Legal Sufficiency

Caroline I. Mockler, Esq.
Staff Counsel, HCSD

5:45 pm, 05/14/2026

EXPLORER K -8

Tim Czyz

Wednesday, April 29, 2026

Prepared For Ando District School

17 Issues Identified



ISSUE 1

Assigned To Entrance By Principal 008

Door 4 @ 5 7/8x 30 3/4

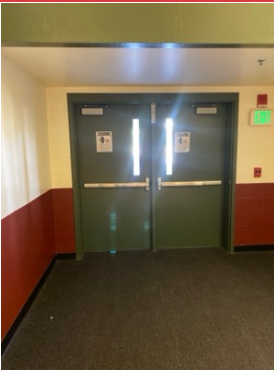

ISSUE 2

Assigned To 605 Entrance

Door 2 @ 2 7/8x 30 3/4



ISSUE 3

Assigned To Entrance By 619 Science Room

Door 2 @ 5 7/8x 30 3/4



ISSUE 4

Assigned To Entrance Next To 034F Administration

Door 4 @ 5 7/8x 30 3/4

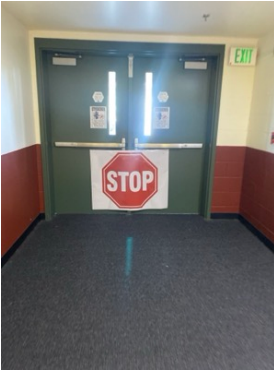

ISSUE 5

Assigned To Entrance 129

Door 2@ 2 7/8x 30 3/4



ISSUE 6

Assigned To Entrance 120

Door 2@ 2 7/8x 30 3/4

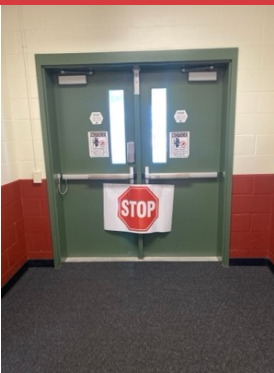

ISSUE 7

Assigned To Entrance By Room 103

Door 2@ 5 7/8x 30 3/4



ISSUE 8

Assigned To Ent 101

Door 2@ 5 7/8x 30 3/4

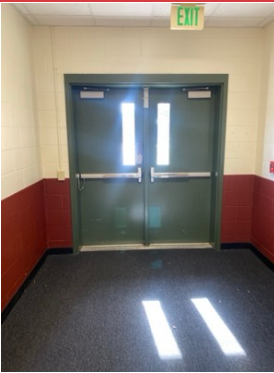

ISSUE 9

Assigned To Entrance By 107 Stairs
Door 2@ 5 7/8x 30 3/4



ISSUE 10

Assigned To 107 Stairs Entrance
Door 2@ 2 7/8x 30 3/4

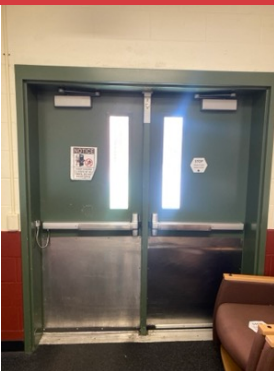

ISSUE 11

Assigned To Entrance By 516 Custodial
Door 2@ 5 7/8x 30 3/4



ISSUE 12

Assigned To Entrance Rate Of Café
Door 2@ 5 7/8x 30 3/4

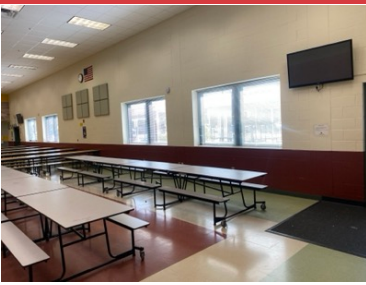

ISSUE 13

Assigned To Cafe

Door 4@ 5 7/8x 30 3/4

Windows 8@ 52 1/2x 56 3/8



ISSUE 14

Assigned To Gymnasium Entrance

Door 4@ 5 7/8x 30 3/4



ISSUE 15

Assigned To Entrance 646

Door 2@ 5 7/8x 30 3/4



ISSUE 16

Assigned To Entrance 631

Door 2@ 2 7/8x 30 3/4

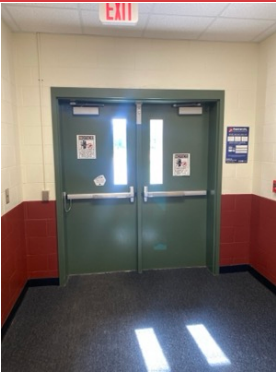

ISSUE 17

Assigned To Ent By 626

Door 2@ 5 7/8x 30 3/4

Armoured One LLC
 386 North Midler Ave.
 Syracuse, NY 13206 US
 +1 3157204186
 ar@armouredone.com
 www.armouredone.com



Quote#: Q-04146

ADDRESS	SHIP TO
Hernando County School District 919 North Broad Street Brooksville FL 34601	Hernando County School District 919 North Broad Street Brooksville FL 34601

Date Provided:

Expires On: 6/30/2026

Purchase Order:

SHIP VIA	Payment Terms	ESTIMATOR	JOB NAME
	Net 30	Joshua Dorschner	Explorer K-8

ACTIVITY	QTY	PRICE	AMOUNT
Film Installation: AOTSF23 SECURITY FILM Ent By Principal 008 - Door : 5 7/8 X 30 3/4	4	\$147.57	\$590.28
Film Installation: AOTSF23 SECURITY FILM 605 Ent - Door : 2 7/8 X 30 3/4	2	\$147.57	\$295.14
Film Installation: AOTSF23 SECURITY FILM Gym Ent - Door : 5 7/8 X 30 3/4	4	\$147.57	\$590.28
Film Installation: AOTSF23 SECURITY FILM Ent By 619 Science Rm - Door : 5 7/8 X 30 3/4	2	\$147.57	\$295.14
Film Installation: AOTSF23 SECURITY FILM Ent Nxt To 034F Admin - Door : 5 7/8 X 30 3/4	4	\$147.57	\$590.28
Film Installation: AOTSF23 SECURITY FILM Ent 129 - Door : 2 7/8 X 30 3/4	2	\$147.57	\$295.14
Film Installation: AOTSF23 SECURITY FILM 107 Stairs Ent - Door : 2 7/8 X 30 3/4	2	\$147.57	\$295.14
Film Installation: AOTSF23 SECURITY FILM Ent 101 - Door : 5 7/8 X 30 3/4	2	\$147.57	\$295.14
Film Installation: AOTSF23 SECURITY FILM Ent 120 - Door : 2 7/8 X 30 3/4	2	\$147.57	\$295.14
Film Installation: AOTSF23 SECURITY FILM Ent By Rm 103 - Door : 5 7/8 X 30 3/4	2	\$147.57	\$295.14
Film Installation: AOTSF23 SECURITY FILM Ent By 107 Stairs - Door : 5 7/8 X 30 3/4	2	\$147.57	\$295.14

IMPORTANT: A finance charge of 1.5% per month (18% per annum) will be charged on past due balances.

ACTIVITY	QTY	PRICE	AMOUNT
Film Installation: AOTSF23 SECURITY FILM Ent By 516 Custodial - Door : 5 7/8 X 30 3/4	2	\$147.57	\$295.14
Film Installation: AOTSF23 SECURITY FILM Ent Rate of Cafe - Door : 5 7/8 X 30 3/4	2	\$147.57	\$295.14
Film Installation: AOTSF23 SECURITY FILM Cafe - Door : 5 7/8 X 30 3/4	4	\$147.57	\$590.28
Film Installation: AOTSF23 SECURITY FILM Ent 646 - Door : 5 7/8 X 30 3/4	2	\$147.57	\$295.14
Film Installation: AOTSF23 SECURITY FILM Ent 631 - Door : 2 7/8 X 30 3/4	2	\$147.57	\$295.14
Film Installation: AOTSF23 SECURITY FILM Ent By 626 - Door : 5 7/8 X 30 3/4	2	\$147.57	\$295.14
Freight	1	\$600.00	\$600.00
Crate	1	\$200.00	\$200.00
Mobility Fee	1	\$900.00	\$900.00
TOTAL:			\$7,897.94

Total Pieces
42.00

Total Square Feet
41.27

Terms & Conditions

Terms: 60% down to do final measure, fabricate product, and deliver on-site. Balance due upon completion of installation.

Includes all products, installation, and prevailing wage.

** Wood stops are not acceptable for the proper function of Shooter/Attack Certified Security film and may require upgraded vision kits.

***installation on glass blocks is not allowed.

Disclaimer: Armoured One's 23 MIL Shooter Attack Film is not "bullet-proof" or "bullet-resistant". It is designed to slow down an attacker with a gun.

Approved as to Legal Sufficiency

Caroline I. Mockler, Esq.
Staff Counsel, HCSD

5:45 pm, 05/14/2026

Accepted By: _____

Accepted Date: ____/____/____

IMPORTANT: A finance charge of 1.5% per month (18% per annum) will be charged on past due balances.

FW SPRINGSTEAD, HIGH SCHOOL

Tim Czyz

Tuesday, April 28, 2026

Prepared For Hernando District Schools

9 Issues Identified

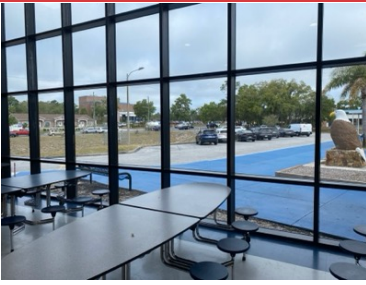

ISSUE 1

Assigned To Cafe

7@ 45 1/4x 59 5/8

7@ 45 1/4x 28 3/4



ISSUE 2

Assigned To Cafe

1@ 56 3/8x 59 5/8

1@ 56 3/8x 28 7/8



ISSUE 3

Assigned To Cafe

1@ 56 3/8x 59 5/8

1@ 56 3/8x 28 7/8



ISSUE 4

Assigned To 100 Teacher Dining

1@ 56 3/8x 59 5/8

1@ 56 3/8x 28 7/8



ISSUE 5

Assigned To 100 Teacher Dining

Door 1 @ 26 1/2x 80 3/4



ISSUE 6

Assigned To 199 Circulation

Door 2 @ 24 1/2x 69

SL 2 @ 49 3/8x 75 1/2

Windows 3 @ 34x 75 1/2

Windows 1 @ 58 1/4x 75 1/2

Windows 1 @ 58 1/8x 75 1/2

Windows 1 @ 58x 75 1/2

Window measurement go from left to right from the outside



ISSUE 7

Assigned To Building 10 Entrance 036

Door 2 @ 31 3/4x 34 3/4

Door 2 @ 31 3/4x 32

SL 1 @ 35 3/4x 45 7/8

SL 1 @ 35 3/4x 30 3/8



ISSUE 8

Assigned To Building 10 Parent Drop Off Site

1 @ 27 3/4x 70 1/4

1 @ 27 3/4x 30 1/2

1 @ 33 7/8x 30 3/4

1 @ 33 7/8x 30 3/8- b

6 @ 30 7/8x 30 3/4

6 @ 30 7/8x 30 1/2- b

Measurements go from left to right from the outside



ISSUE 9

Assigned To Building 10 Parent Drop Off Site

SL 1 @ 11 7/8x 70 1/2

SL 1 @ 11 7/8x 30 1/4

Windows 1 @ 33 7/8x 30 5/8

Windows 1 @ 33 7/8x 30 1/4- b

Windows 6 @ 30 7/8x 30 5/8

Windows 6 @ 30 7/8x 30 5/8- b

Windows 2 @ 34 1/8x 30 5/8

Windows 2 @ 34 1/8x 30 1/4- b

SL 2 @ 13x 70 1/2

SL 2 @ 13x 30 1/4

Windows 3 @ 30 7/8 x 30 5/8

Windows 3 @ 30 7/8x 30 5/8

SL 1 @ 21x 70 1/2

SL 1 @ 21x 30 3/8

Windows 6 @ 30 7/8x 30 5/8

Window measurements go from left to right from the outside

Armoured One LLC
 386 North Midler Ave.
 Syracuse, NY 13206 US
 +1 3157204186
 ar@armouredone.com
 www.armouredone.com



Quote#: Q-04153

ADDRESS	SHIP TO
Hernando County School District 919 North Broad Street Brooksville FL 34601	Hernando County School District 919 North Broad Street Brooksville FL 34601

Date Provided:

Expires On: 6/30/2026

Purchase Order:

SHIP VIA	Payment Terms	ESTIMATOR	JOB NAME
	Net 30	Joshua Dorschner	F.W Springstead High School

ACTIVITY	QTY	PRICE	AMOUNT
Film Installation: AOTSF23 SECURITY FILM 100 Teacher Dining - Door : 26 1/2 X 80 3/4	1	\$691.89	\$691.89
Film Installation: AOTSF23 SECURITY FILM Cafe - Window : 45 1/4 X 59 5/8	7	\$872.36	\$6,106.52
Film Installation: AOTSF23 SECURITY FILM Cafe - Window : 45 1/4 X 28 3/4	7	\$420.64	\$2,944.48
Film Installation: AOTSF23 SECURITY FILM Cafe - Window : 56 3/8 X 59 5/8	1	\$1,086.84	\$1,086.84
Film Installation: AOTSF23 SECURITY FILM Cafe - Window : 56 3/8 X 28 7/8	1	\$526.33	\$526.33
Film Installation: AOTSF23 SECURITY FILM Cafe - Window : 56 3/8 X 59 5/8	1	\$1,086.84	\$1,086.84
Film Installation: AOTSF23 SECURITY FILM Cafe - Window : 56 3/8 X 28 7/8	1	\$526.33	\$526.33
Film Installation: AOTSF23 SECURITY FILM 100 Teacher Dining - Window : 56 3/8 X 59 5/8	1	\$1,086.84	\$1,086.84
Film Installation: AOTSF23 SECURITY FILM 100 Teacher Dining - Window : 56 3/8 X 28 7/8	1	\$526.33	\$526.33
Film Installation: AOTSF23 SECURITY FILM 199 Circulation - Door : 24 1/2 X 69	2	\$546.59	\$1,093.18

IMPORTANT: A finance charge of 1.5% per month (18% per annum) will be charged on past due balances.

ACTIVITY	QTY	PRICE	AMOUNT
Film Installation: AOTSF23 SECURITY FILM 199 Circulation - SL : 49 3/8 X 75 1/2	2	\$1,205.33	\$2,410.66
Film Installation: AOTSF23 SECURITY FILM Building 10 Entrance 036 - Door : 31 3/4 X 34 3/4	2	\$356.74	\$713.48
Film Installation: AOTSF23 SECURITY FILM Building 10 Entrance 036 - Door : 31 3/4 X 32	2	\$328.51	\$657.02
Film Installation: AOTSF23 SECURITY FILM Building 10 Entrance 036 - SL : 35 3/4 X 45 7/8	1	\$530.28	\$530.28
Film Installation: AOTSF23 SECURITY FILM Building 10 Entrance 036 - SL : 35 3/4 X 30 3/8	1	\$351.11	\$351.11
Film Installation: AOTSF23 SECURITY FILM Building 10 Parent Drop Off Site - SL : 27 3/4 X 70 1/4	1	\$630.32	\$630.32
Film Installation: AOTSF23 SECURITY FILM Building 10 Parent Drop Off Site - SL : 27 3/4 X 30 1/2	1	\$273.66	\$273.66
Film Installation: AOTSF23 SECURITY FILM Building 10 Parent Drop off Site - SL : 11 7/8 X 70 1/2	1	\$270.69	\$270.69
Film Installation: AOTSF23 SECURITY FILM Building 10 Parent Drop off Site - SL : 11 7/8 X 30 1/4	1	\$139.68	\$139.68
Film Installation: AOTSF23 SECURITY FILM Building 10 Parent Drop off Site - SL : 13 X 70 1/2	2	\$296.33	\$592.66
Film Installation: AOTSF23 SECURITY FILM Building 10 Parent Drop off Site - SL : 13 X 30 1/4	2	\$139.68	\$279.36
Film Installation: AOTSF23 SECURITY FILM Building 10 Parent Drop off Site - SL : 21 X 70 1/2	1	\$478.70	\$478.70
Film Installation: AOTSF23 SECURITY FILM Building 10 Parent Drop off Site - SL : 21 X 30 3/8	1	\$206.25	\$206.25
Freight	1	\$600.00	\$600.00
Crate	1	\$200.00	\$200.00
Mobility Fee	1	\$2,600.00	\$2,600.00
TOTAL:			\$26,609.45

IMPORTANT: A finance charge of 1.5% per month (18% per annum) will be charged on past due balances.

Total Pieces
41.00

Total Square Feet
497.44

Terms & Conditions

Terms: 60% down to do final measure, fabricate product, and deliver on-site. Balance due upon completion of installation.

Includes all products, installation, and prevailing wage.

** Wood stops are not acceptable for the proper function of Shooter/Attack Certified Security film and may require upgraded vision kits.

***installation on glass blocks is not allowed.

Disclaimer: Armoured One's 23 MIL Shooter Attack Film is not "bullet-proof" or "bullet-resistant". It is designed to slow down an attacker with a gun.

Accepted By: _____

Accepted Date: ____/____/____

Approved as to Legal Sufficiency
Caroline I. Mockler, Esq.
Staff Counsel, HCSD
5:45 pm, 05/14/2026

FOX CHAPEL MIDDLE SCHOOL

Tim Czyz

Wednesday, April 29, 2026

Prepared For Hernando District Schools

21 Issues Identified



ISSUE 1

Assigned To Building 10 Entrances

Door 4 @ 23 1/2x 63

SL 2 @ 28 1/4x 37

SL 2 @ 28 1/4x 36 3/4- b

SI 2 @ 27 3/4x 37-fieldside

SL 2 @ 27 3/4x 36 3/4- b-fieldside

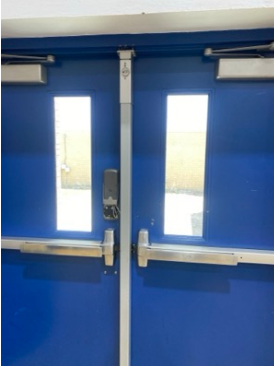

ISSUE 2

Assigned To Gymnasium

Door 2 @ 8 1/2x 29 3/4

Take apart, clip type



ISSUE 3

Assigned To Gymnasium

Door 2 @ 4 3/4x 31 3/4

Film removal



ISSUE 4

Assigned To Gymnasium

Door 2 @ 4 3/4x 31 5/8

Film removal

Left door glass is cracked



ISSUE 5

Assigned To Gymnasium Rear Entrance

Door 2@ 4 3/4x 31 1/2

Film removal



ISSUE 6

Assigned To Gymnasium Concession Entrance

Door 4@ 18 1/4x 70 1/4

Film removal



ISSUE 7

Assigned To Building Five Entrance

Door 2@ 22 3/4x 62 1/4



ISSUE 8

Assigned To Building Five Entrance Middle

Door 2@ 24 1/2x 65



ISSUE 9

Assigned To Building Five Entrance
Door 2@ 5 3/4x 20 3/4



ISSUE 10

Assigned To Building One Entrances
Door 2@ 23 1/2x 63
SL 2@ 6 1/4x 37
SL 2@ 6 1/4x 36 3/4- b



ISSUE 11

Assigned To Building One Entrance Parking Lot Side
Door 2@ 24 1/2x 69
SI 2@ 7 3/4x 47 3/4
SL 2@ 32 1/4-b



ISSUE 12

Assigned To Building Two Entrances
Door 4@ 23 1/2x 63
SL 4@ 6 1/2x 37 1/8
SL 4@ 6 1/2x 36 3/4



ISSUE 13

Assigned To Library
Door 6@ 24 1/4x 70 1/4



ISSUE 14

Assigned To Library Safe Area Entrance
Door 1@ 6 3/4x 30 1/2
Take apart



ISSUE 15

Assigned To Entrance By Janitor Building Three
Door 2@ 24 1/2x 69



ISSUE 16

Assigned To Building Three Entrance By Room 001B Parking Lot Side
Door 2@ 23 1/2x 75 7/8
SL 2@ 6 1/2x 49 7/8
SL 2@ 6 1/2x 36 3/4



ISSUE 17

Assigned To Rm 005 Ent

Door 1 @ 30 1/2x 75 7/8

Static film removal



ISSUE 18

Assigned To Building Three Foyer

Door 2 @ 23 1/2x 74 3/4

SL 1 @ 44 3/4x 48 7/8

SL 1 @ 44 3/4x 36 3/4



ISSUE 19

Assigned To Café

Door 2 @ 24 1/2x 69



ISSUE 20

Assigned To Cafe

Door 2 @ 24 1/2x 69

SL 1 @ 43 5/8x 55

SL 1 @ 43 5/8x 32 1/2

SL 1 @ 10 x 55

SL 1 @ 10x 32 1/2

Film removal on side lights



ISSUE 21

Assigned To Principals Office

Door 1 @ 24 1/4x 33 7/8

Door 1 @ 24 1/4x 28

Film removal

Armoured One LLC
 386 North Midler Ave.
 Syracuse, NY 13206 US
 +1 3157204186
 ar@armouredone.com
 www.armouredone.com



Quote#: Q-04166

ADDRESS

Hernando County School District
 919 North Broad Street
 Brooksville
 FL
 34601

SHIP TO

Hernando County School District
 919 North Broad Street
 Brooksville
 FL
 34601

Date Provided:

Expires On: 6/30/2026

Purchase Order:

SHIP VIA

Payment Terms
 Net 30

ESTIMATOR
 Joshua Dorschner

JOB NAME
 Fox Chapel Middle School

ACTIVITY	QTY	PRICE	AMOUNT
Film Installation: AOTSF23 SECURITY FILM Gym - Door : 8 1/2 X 29 3/4	2	\$138.36	\$276.72
Film Installation: AOTSF23 SECURITY FILM Gym - Door : 4 3/4 X 31 3/4	2	\$138.36	\$276.72
Film Installation: AOTSF23 SECURITY FILM Gym - Door : 4 3/4 X 31 5/8	2	\$138.36	\$276.72
Film Installation: AOTSF23 SECURITY FILM Gym Rear Ent - Door : 4 3/4 X 31 1/2	2	\$138.36	\$276.72
Film Installation: AOTSF23 SECURITY FILM Gym Concession Ent - Door : 18 1/4 X 70 1/4	4	\$410.62	\$1,642.48
Film Installation: AOTSF23 SECURITY FILM Cafe - Door : 24 1/2 X 69	2	\$541.43	\$1,082.86
Film Installation: AOTSF23 SECURITY FILM Cafe - SL : 43 5/8 X 55	1	\$768.47	\$768.47
Film Installation: AOTSF23 SECURITY FILM Cafe - SL : 43 5/8 X 32 1/2	1	\$454.09	\$454.09
Film Installation: AOTSF23 SECURITY FILM Cafe - SL : 10 X 55	1	\$176.15	\$176.15
Film Installation: AOTSF23 SECURITY FILM Cafe - SL : 10 X 32 1/2	1	\$138.36	\$138.36

IMPORTANT: A finance charge of 1.5% per month (18% per annum) will be charged on past due balances.

ACTIVITY	QTY	PRICE	AMOUNT
Film Installation: AOTSF23 SECURITY FILM Cafe - Door : 24 1/2 X 69	2	\$541.43	\$1,082.86
Film Installation: AOTSF23 SECURITY FILM Library - Door : 24 1/4 X 70 1/4	6	\$545.61	\$3,273.66
Film Installation: AOTSF23 SECURITY FILM Lib Safe Area Ent - Door : 6 3/4 X 30 1/2	1	\$138.36	\$138.36
Film Installation: AOTSF23 SECURITY FILM Ent By Janitor Building 3 - Door : 24 1/2 X 69	2	\$541.43	\$1,082.86
Film Installation: AOTSF23 SECURITY FILM Building 3 Ent By Rm 001B Parking Lot - Door : 23 1/2 X 75 7/8	2	\$571.08	\$1,142.16
Film Installation: AOTSF23 SECURITY FILM Building 3 Ent By Rm 001B Parking Lot - SL : 6 1/2 X 49 7/8	2	\$138.36	\$276.72
Film Installation: AOTSF23 SECURITY FILM Building 3 Ent By Rm 001B Parking Lot - SL : 6 1/2 X 36 3/4	2	\$138.36	\$276.72
Film Installation: AOTSF23 SECURITY FILM Rm 005 Ent - Door : 30 1/2 X 75 7/8	1	\$741.18	\$741.18
Film Installation: AOTSF23 SECURITY FILM Building 3 Foyer - Door : 23 1/2 X 74 3/4	2	\$562.61	\$1,125.22
Film Installation: AOTSF23 SECURITY FILM Building 3 Foyer - SL : 44 3/4 X 48 7/8	1	\$700.50	\$700.50
Film Installation: AOTSF23 SECURITY FILM Building 3 Foyer - SL : 44 3/4 X 36 3/4	1	\$526.72	\$526.72
Film Installation: AOTSF23 SECURITY FILM Principal Off - Door : 24 1/4 X 33 7/8	1	\$263.10	\$263.10
Film Installation: AOTSF23 SECURITY FILM Principal Off - Door : 24 1/4 X 28	1	\$217.47	\$217.47
Freight	1	\$600.00	\$600.00
Crate	1	\$200.00	\$200.00
Mobility Fee	1	\$1,500.00	\$1,500.00
TOTAL:			\$18,516.82

Total Pieces
42.00

Total Square Feet
253.33

Terms & Conditions

Terms: 60% down to do final measure, fabricate product, and deliver on-site. Balance due upon completion of installation.

Includes all products, installation, and prevailing wage.

** Wood stops are not acceptable for the proper function of Shooter/Attack Certified Security film and may require upgraded vision kits.

***installation on glass blocks is not allowed.

Disclaimer: Armoured One's 23 MIL Shooter Attack Film is not "bullet-proof" or "bullet-resistant". It is designed to slow down an attacker with a gun.

Accepted By: _____

Accepted Date: ____/____/____

Approved as to Legal Sufficiency

Caroline I. Mockler, Esq.
Staff Counsel, HCSD

5:45 pm, 05/14/2026

HERNANDO HIGH SCHOOL

Tim Czyz

Friday, May 1, 2026

Prepared For Hernando District Schools

11 Issues Identified



ISSUE 1

Assigned To Main Ent

SL 6@ 31 3/4x 25 3/4

For some reason, these sidelights were not done on original vestibule Work



ISSUE 2

Assigned To Gymnasium, Foyer

Door 6@ 24 1/2x 34 7/8

Door 6@ 24 1/2x 26- 4 are missing top stops

SL 2@ 50x 40 1/8

SL 2@ 47 1/4x 40 1/8

SL 2@ 46 5/8x 40

SL 2@ 49 3/4x 40

Tint removal

Satellite measurements go from left to right from the inside



ISSUE 3

Assigned To Entrance By 25-5 14 Gymnasium Area

Door 8@ 7 3/4x 6 1/2



ISSUE 4

Assigned To Theater Entrance

Door 2@ 27 1/2x 82

SL 2@ 36 1/2x 93 5/8



ISSUE 5

Assigned To Theater

Door 2@ 27 1/8x 82

Door 2@ 24 1/8x 45 7/8

Door 2@ 24 1/8x 25 3/4



ISSUE 6

Assigned To Cafeteria Entrance By Outside Dining

Door 4@ 23x 23- take apart - two need film removal

SL 2@ 24 1/2x 46 1/2

SL 2@ 24 1/2x 28 1/4

SL 1@ 6 1/2x 46 1/2

SL 1@ 6 1/2x 28 1/2



ISSUE 7

Assigned To Cafeteria Main Entrance

Door 2@ 23 3/4x 31 3/4

Door 2@ 23 3/4x 22 3/4

SL 2@ 29 1/2x 46 1/2

SL 2@ 29 1/2x 28 1/2

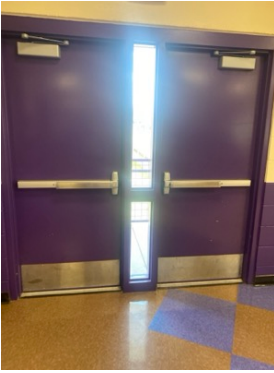

ISSUE 8

Assigned To Cafeteria

SL 1@ 6 1/2x 44 1/2

SL 1@ 6 1/2x 28 1/2



ISSUE 9

Assigned To Building 17 Drama Room

Door 2@ 6 1/4x 36 1/4- take apart

Pervy paint

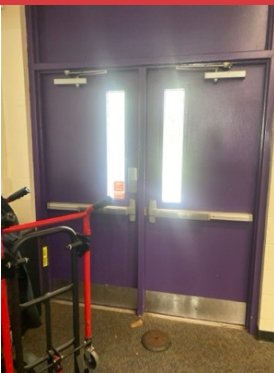

ISSUE 10

Assigned To Building 17 Band Room

Door 2@ 6 1/4x 36 1/4- take apart

Heavy paint



ISSUE 11

Assigned To Library

Door 2@ 24 1/2x 69

SL 1@ 39 3/4x 70 1/4

SL 1@ 39 3/4x 32 1/8

SL 1@ 20 3/4x 70 1/4

SL 1@ 20 3/4x 32 1/8

Door 2@ 27x 71 3/4

SL 1@ 20 3/4x 70 1/2

SL 1@ 20 3/4x 32 1/4

SL 1@ 39 3/4x 70 1/2

SL 1@ 39 3/4x 32 1/4

Measurements are from left to right from inside

Armoured One LLC
 386 North Midler Ave.
 Syracuse, NY 13206 US
 +1 3157204186
 ar@armouredone.com
 www.armouredone.com



Quote#: Q-04127

ADDRESS	SHIP TO
Hernando County School District 919 North Broad Street Brooksville FL 34601	Hernando County School District 919 North Broad Street Brooksville FL 34601

Date Provided:

Expires On: 6/30/2026

Purchase Order:

SHIP VIA	Payment Terms	ESTIMATOR	JOB NAME
	Net 30	Joshua Dorschner	Hernando High School

ACTIVITY	QTY	PRICE	AMOUNT
Film Installation: AOTSF23 SECURITY FILM Theater Ent - Door : 27 1/2 X 82	2	\$720.50	\$1,441.00
Film Installation: AOTSF23 SECURITY FILM Theater Ent - SL : 36 1/2 X 93 5/8	2	\$1,091.88	\$2,183.76
Film Installation: AOTSF23 SECURITY FILM Main Ent - SL : 31 3/4 X 25 3/4	6	\$261.22	\$1,567.32
Film Installation: AOTSF23 SECURITY FILM Ent By 25-5 14 Gym Area - Door : 7 3/4 X 6 1/2	4	\$138.03	\$552.12
Film Installation: AOTSF23 SECURITY FILM Gym Foyer - Door : 24 1/2 X 34 7/8	6	\$273.00	\$1,638.00
Film Installation: AOTSF23 SECURITY FILM Gym Foyer - D : 24 1/2 X 26	6	\$203.53	\$1,221.18
Film Installation: AOTSF23 SECURITY FILM Gym Foyer - SL : 50 X 40 1/8	2	\$641.02	\$1,282.04
Film Installation: AOTSF23 SECURITY FILM Gym Foyer - SL : 47 1/4 X 40 1/8	2	\$605.77	\$1,211.54
Film Installation: AOTSF23 SECURITY FILM Gym Foyer - SL : 46 5/8 X 40	2	\$595.89	\$1,191.78
Film Installation: AOTSF23 SECURITY FILM Gym Foyer - SL : 49 3/4 X 40	2	\$635.83	\$1,271.66

IMPORTANT: A finance charge of 1.5% per month (18% per annum) will be charged on past due balances.

ACTIVITY	QTY	PRICE	AMOUNT
Film Installation: AOTSF23 SECURITY FILM Theater - Door : 27 1/8 X 82	2	\$710.68	\$1,421.36
Film Installation: AOTSF23 SECURITY FILM Theater - Door : 24 1/8 X 45 7/8	2	\$353.62	\$707.24
Film Installation: AOTSF23 SECURITY FILM Theater - Door : 24 1/8 X 25 3/4	2	\$198.49	\$396.98
Freight	1	\$600.00	\$600.00
Crate	1	\$200.00	\$200.00
Mobility Fee	1	\$2,000.00	\$2,000.00
TOTAL:			\$18,885.98

Total Pieces
40.00

Total Square Feet
339.02

Terms & Conditions

Terms: 60% down to do final measure, fabricate product, and deliver on-site. Balance due upon completion of installation.

Includes all products, installation, and prevailing wage.

** Wood stops are not acceptable for the proper function of Shooter/Attack Certified Security film and may require upgraded vision kits.

***installation on glass blocks is not allowed.

Disclaimer: Armoured One's 23 MIL Shooter Attack Film is not "bullet-proof" or "bullet-resistant". It is designed to slow down an attacker with a gun.

Accepted By: _____

Accepted Date: ____/____/____

Approved as to Legal Sufficiency
Caroline I. Mockler, Esq.
Staff Counsel, HCSD
5:44 pm, 05/14/2026

JD FLOYD ELEMENTARY SCHOOL

Tim Czyz

Thursday, April 30, 2026

Prepared For Hernando District Schools

6 Issues Identified



ISSUE 1

Assigned To Main Office Ent

SL 1 @ 23 1/8x 68 1/2

SL 1 @ 23 1/8x 18 1/8

SL 1 @ 63 3/8x 68 1/2

SL 1 @ 63 3/8x 18 1/8



ISSUE 2

Assigned To Building 12 Entrances Both Ends Of The Hallway

Door 4 @ 22 3/4x 30 7/8



ISSUE 3

Assigned To Building 13 Both Ends Of Hallway

Door 4 @ 22 3/4x 30 7/8



ISSUE 4

Assigned To Building 12 Stairwell Doors

Door 2 @ 18 7/8x 30 3/4



ISSUE 5

Assigned To Library Parking Lot Side

SL 1@ 63 1/8x 68 3/8

SL 1@ 63 1/8x 18 1/4

SL 1@ 23 1/8x 68 3/8

SL 1@ 23 1/8x 18 1/4



ISSUE 6

Assigned To Principals Office

Door 1@ 24 3/8x 79 1/4

SL 1@ 19 1/2x 68 1/2

SL 1@ 19 1/2x 18 1/8

Tint removal

Armoured One LLC
 386 North Midler Ave.
 Syracuse, NY 13206 US
 +1 3157204186
 ar@armouredone.com
 www.armouredone.com



Quote#: Q-04100

ADDRESS	SHIP TO
Hernando County School District 919 North Broad Street Brooksville FL 34601	Hernando County School District 919 North Broad Street Brooksville FL 34601

Date Provided:

Expires On: 6/30/2026

Purchase Order:

SHIP VIA	Payment Terms	ESTIMATOR	JOB NAME
	Net 30	Joshua Dorschner	JD Floyd Elementary School

ACTIVITY	QTY	PRICE	AMOUNT
Film Installation: AOTSF23 SECURITY FILM Library Parking Lot Side - SL : 63 1/8 X 68 3/8	1	\$1,380.88	\$1,380.88
Film Installation: AOTSF23 SECURITY FILM Library Parking Lot Side - SL : 63 1/8 X 18 1/4	1	\$368.57	\$368.57
Film Installation: AOTSF23 SECURITY FILM Library Parking Lot Side - SL : 23 1/8 X 68 3/8	1	\$505.87	\$505.87
Film Installation: AOTSF23 SECURITY FILM Library Parking Lot Side - SL : 23 1/8 X 18 1/4	1	\$138.21	\$138.21
Film Installation: AOTSF23 SECURITY FILM Main Office Entrance - SL : 23 1/8 X 68 1/2	1	\$506.79	\$506.79
Film Installation: AOTSF23 SECURITY FILM Main Office Entrance - SL : 23 1/8 X 18 1/8	1	\$138.21	\$138.21
Film Installation: AOTSF23 SECURITY FILM Main Office Entrance - SL : 63 3/8 X 68 1/2	1	\$1,388.88	\$1,388.88
Film Installation: AOTSF23 SECURITY FILM Main Office Entrance - SL : 63 3/8 X 18 1/8	1	\$367.50	\$367.50
Film Installation: AOTSF23 SECURITY FILM Building 12 Entrances Both Ends of Hallway - Door : 22 3/4 X 30 7/8	4	\$224.72	\$898.88
Film Installation: AOTSF23 SECURITY FILM Building 13 Both Ends of Hallway - Door : 22 3/4 X 30 7/8	4	\$224.72	\$898.88

IMPORTANT: A finance charge of 1.5% per month (18% per annum) will be charged on past due balances.

ACTIVITY	QTY	PRICE	AMOUNT
Film Installation: AOTSF23 SECURITY FILM Building 12 Stairwell Doors - Door : 18 7/8 X 30 3/4	2	\$185.69	\$371.38
Film Installation: AOTSF23 SECURITY FILM Principals Office - Door : 24 3/8 X 79 1/4	1	\$618.02	\$618.02
Film Installation: AOTSF23 SECURITY FILM Principals Office - SL : 19 1/2 X 68 1/2	1	\$427.35	\$427.35
Film Installation: AOTSF23 SECURITY FILM Principals Office - SL : 19 1/2 X 18 1/8	1	\$138.21	\$138.21
Freight	1	\$600.00	\$600.00
Crate	1	\$200.00	\$200.00
Mobility Fee	1	\$800.00	\$800.00
TOTAL:			\$9,747.63

Total Pieces
21.00

Total Square Feet
176.15

Terms & Conditions

Terms: 60% down to do final measure, fabricate product, and deliver on-site. Balance due upon completion of installation.

Includes all products, installation, and prevailing wage.

** Wood stops are not acceptable for the proper function of Shooter/Attack Certified Security film and may require upgraded vision kits.

***installation on glass blocks is not allowed.

Disclaimer: Armoured One's 23 MIL Shooter Attack Film is not "bullet-proof" or "bullet-resistant". It is designed to slow down an attacker with a gun.

Accepted By: _____

Accepted Date: ____/____/____

Approved as to Legal Sufficiency

Caroline I. Mockler, Esq.
Staff Counsel, HCSD

5:44 pm, 05/14/2026

MOTON ELEMENTARY SCHOOL

Tim Czyz

Friday, May 1, 2026

Prepared For Hernando District Schools

10 Issues Identified



ISSUE 1

Assigned To Ent 1-100 Hallway Doors

Door 4 @ 24 1/4x 67 3/8



ISSUE 2

Assigned To Building Two Hallway Doors

4 @ 24 1/4x 67 1/2

Tint removal



ISSUE 3

Assigned To Building Three Hallway Doors

Door 4 @ 24 1/4x 67 3/8

Tint removal



ISSUE 4

Assigned To Café

Door 8 @ 24 1/4x 67 3/8

Tint removal



ISSUE 5

Assigned To Entrance By Five Music
Door 2@ 24 1/4x 67 3/8



ISSUE 6

Assigned To Entrance By Room 4-401 Building Four
Door 2@ 2 3/4x 34 3/4



ISSUE 7

Assigned To Building Four, Entrance By Room 407
Door 2@ 24 1/4x 67 3/8
Tint removal



ISSUE 8

Assigned To Library Storage Area
Door 1@ 24 1/4x 67 3/8



ISSUE 9

Assigned To Library

Door 2@ 24 1/4x 67 3/8



ISSUE 10

Assigned To Building One Middle Entrance

Door 2@ 24 1/4x 67 3/8

Tint removal

Armoured One LLC
 386 North Midler Ave.
 Syracuse, NY 13206 US
 +1 3157204186
 ar@armouredone.com
 www.armouredone.com



Quote#: Q-04131

ADDRESS	SHIP TO
Hernando County School District 919 North Broad Street Brooksville FL 34601	Hernando County School District 919 North Broad Street Brooksville FL 34601

Date Provided:

Expires On: 6/30/2026

Purchase Order:

SHIP VIA	Payment Terms	ESTIMATOR	JOB NAME
	Net 30	Joshua Dorschner	Moton Elementary School

ACTIVITY	QTY	PRICE	AMOUNT
Film Installation: AOTSF23 SECURITY FILM Lib Storage Area - Door : 24 1/4 X 67 3/8	1	\$522.60	\$522.60
Film Installation: AOTSF23 SECURITY FILM Ent 1-100 - Hallway Doors : 24 1/4 X 67 3/8	4	\$522.60	\$2,090.40
Film Installation: AOTSF23 SECURITY FILM Building 2 Hallway - Door : 24 1/4 X 67 1/2	4	\$523.57	\$2,094.28
Film Installation: AOTSF23 SECURITY FILM Building 3 Hallway - Door : 24 1/4 X 67 3/8	4	\$522.60	\$2,090.40
Film Installation: AOTSF23 SECURITY FILM Cafe - Door : 24 1/4 X 67 3/8	8	\$522.60	\$4,180.80
Film Installation: AOTSF23 SECURITY FILM Ent By 5 Music - Door : 24 1/4 X 67 3/4	2	\$525.51	\$1,051.02
Film Installation: AOTSF23 SECURITY FILM Ent By Rm 4-401 Bldg 4 - Door : 2 3/4 X 34 3/4	2	\$138.18	\$276.36
Film Installation: AOTSF23 SECURITY FILM Bldg 4 Ent By Rm 407 - Door : 24 1/4 X 67 3/8	2	\$522.60	\$1,045.20
Film Installation: AOTSF23 SECURITY FILM Library - Door : 24 1/4 X 67 3/8	2	\$522.60	\$1,045.20
Film Installation: AOTSF23 SECURITY FILM Building 1 Mid School - Door : 24 1/4 X 67 3/8	2	\$522.60	\$1,045.20
Freight	1	\$600.00	\$600.00
Crate	1	\$200.00	\$200.00

IMPORTANT: A finance charge of 1.5% per month (18% per annum) will be charged on past due balances.

ACTIVITY	QTY	PRICE	AMOUNT
Mobility Fee	1	\$2,000.00	\$2,000.00
TOTAL:			\$18,241.46

Total Pieces
31.00

Total Square Feet
330.58

Terms & Conditions

Terms: 60% down to do final measure, fabricate product, and deliver on-site. Balance due upon completion of installation.

Includes all products, installation, and prevailing wage.

** Wood stops are not acceptable for the proper function of Shooter/Attack Certified Security film and may require upgraded vision kits.

***installation on glass blocks is not allowed.

Disclaimer: Armoured One's 23 MIL Shooter Attack Film is not "bullet-proof" or "bullet-resistant". It is designed to slow down an attacker with a gun.

Accepted By: _____

Accepted Date: ____/____/____

Approved as to Legal Sufficiency
 Caroline I. Mockler, Esq.
 Staff Counsel, HCSD
 5:44 pm, 05/14/2026

PINE GROVE ELEMENTARY SCHOOL

Tim Czyz

Tuesday, April 28, 2026

Prepared For Hernando District School

11 Issues Identified



ISSUE 1

Assigned To Cafe

Door 8@ 28 3/4x 77 1/4- take apart heavy paint



ISSUE 2

Assigned To Cafe

Windows 5@ 52 1/4x 51 1/4

Windows 5@ 52 1/4x 28 1/8



ISSUE 3

Assigned To Cafe

SL 1@ 19 3/8x 68 1/2

SL 1@ 19 3/8x 18 1/4



ISSUE 4

Assigned To Cafe

Windows 2@ 38 5/8x 20 1/8- top

Windows 2@ 38 5/8x 19 3/4

Windows 2@ 38 5/8x 19 3/4



ISSUE 5

Assigned To Cafe

Door 2@ 21 3/4x 31 3/4



ISSUE 6

Assigned To Media Center

SL 1@ 21 1/8x 68 1/4

SL 1@ 21 1/8x 18 1/8

SL 1@ 59x 68 1/4

SL 1@ 59x 18 1/8



ISSUE 7

Assigned To Media Center

4@ 39 3/8x 20

2@ 39 3/8x 19 3/4- b

4@ 41 3/8x 20

2@ 41 3/8x 19 3/4- b



ISSUE 8

Assigned To Media Center

4@ 38 1/2x 20

2@ 38 1/2x 19 3/4- b

6@ 39 7/8x 20

3@ 39 7/8x 19 3/4-

Measurements go from left to right from the outside



ISSUE 9

Assigned To Administration Office

Door 1 @ 24 3/4x 77 1/4- take apart, heavy paint, tint removal

SL 1 @ 19 1/4x 68 3/8

SL 1 @ 19 1/4x 18 1/8



ISSUE 10

Assigned To Admin

Windows 4 @ 34x 20

Windows 2 @ 34x 19 3/4- b



ISSUE 11

Assigned To Administration

2 @ 38x 20

1 @ 38x 19 3/4- b

2 @ 41 3/8x 20

1 @ 41 3/8x 19 3/4- b

2 @ 39 3/8x 20

1 @ 39 3/8x 19 3/4- b

Left or right measurements from outside

Armoured One LLC
 386 North Midler Ave.
 Syracuse, NY 13206 US
 +1 3157204186
 ar@armouredone.com
 www.armouredone.com



Quote#: Q-04154

ADDRESS	SHIP TO
Hernando County School District 919 North Broad Street Brooksville FL 34601	Hernando County School District 919 North Broad Street Brooksville FL 34601

Date Provided:

Expires On: 6/30/2026

Purchase Order:

SHIP VIA	Payment Terms	ESTIMATOR	JOB NAME
	Net 30	Joshua Dorschner	Pine Grove Elementary School

ACTIVITY	QTY	PRICE	AMOUNT
Film Installation: AOTSF23 SECURITY FILM Admin Office - Door : 24 3/4 X 77 1/4	1	\$610.89	\$610.89
Film Installation: AOTSF23 SECURITY FILM Cafe - Door : 28 3/4 X 77 1/4	8	\$709.62	\$5,676.96
Film Installation: AOTSF23 SECURITY FILM Media Center - SL : 21 1/8 X 68 1/4	1	\$460.67	\$460.67
Film Installation: AOTSF23 SECURITY FILM Media Center - SL : 21 1/8 X 18 1/8	1	\$138.03	\$138.03
Film Installation: AOTSF23 SECURITY FILM Media Center - SL : 59 X 68 1/4	1	\$1,286.60	\$1,286.60
Film Installation: AOTSF23 SECURITY FILM Media Center - SL : 59 X 18 1/8	1	\$341.68	\$341.68
Film Installation: AOTSF23 SECURITY FILM Cafe - SL : 19 3/8 X 68 1/2	1	\$424.05	\$424.05
Film Installation: AOTSF23 SECURITY FILM Cafe - SL : 19 3/8 X 18 1/4	1	\$138.03	\$138.03
Film Installation: AOTSF23 SECURITY FILM Admin Office - SL : 19 1/4 X 68 3/8	1	\$420.55	\$420.55
Film Installation: AOTSF23 SECURITY FILM Admin Office - SL : 19 1/4 X 18 1/8	1	\$138.03	\$138.03

IMPORTANT: A finance charge of 1.5% per month (18% per annum) will be charged on past due balances.

ACTIVITY	QTY	PRICE	AMOUNT
Film Installation: AOTSF23 SECURITY FILM Cafe - Door : 21 3/4 X 31 3/4	2	\$220.64	\$441.28
Film Installation: AOTSF23 SECURITY FILM Cafe - Window : 52 1/4 X 51 1/4	5	\$855.60	\$4,278.00
Film Installation: AOTSF23 SECURITY FILM Cafe - Window : 52 1/4 X 28 1/8	5	\$469.54	\$2,347.70
Freight	1	\$600.00	\$600.00
Mobility Fee	1	\$2,000.00	\$2,000.00
Crate	1	\$200.00	\$200.00
TOTAL:			\$19,502.47

Total Pieces
29.00

Total Square Feet
361.56

Terms & Conditions

Terms: 60% down to do final measure, fabricate product, and deliver on-site. Balance due upon completion of installation.

Includes all products, installation, and prevailing wage.

** Wood stops are not acceptable for the proper function of Shooter/Attack Certified Security film and may require upgraded vision kits.

***installation on glass blocks is not allowed.

Disclaimer: Armoured One's 23 MIL Shooter Attack Film is not "bullet-proof" or "bullet-resistant". It is designed to slow down an attacker with a gun.

Accepted By: _____

Accepted Date: ____/____/____

Approved as to Legal Sufficiency
 Caroline I. Mockler, Esq.
 Staff Counsel, HCSD
 5:44 pm, 05/14/2026

POWELL MIDDLE SCHOOL

Tim Czyz

Thursday, April 30, 2026

Prepared For Hernando District Schools

6 Issues Identified



ISSUE 1

Assigned To Main Office Outer Windows

Windows 8@ 18 1/4x 40 3/4

Windows 1@ 18 5/8x 48

Windows 1@ 19c 48



ISSUE 2

Assigned To Library

Door 4@ 24 1/4x 70

SL 2@ 19 1/8x 51 1/4



ISSUE 3

Assigned To Gymnasium

Door 6@ 4 1/2x 25 3/4

Take apart



ISSUE 4

Assigned To Gymnasium Foyer Rear Entrance

Door 2@ 4 1/2x 25 3/4

Take apart



ISSUE 5

Assigned To Gymnasium Main Entrance

Door 2@ 24 1/2x 67

SL 2@ 23 7/8x 53

SL 2@ 23 7/8x 26 1/2



ISSUE 6

Assigned To Cafeteria

Door 4@ 24 1/2x 69

SL 3@ 19 1/4x 38 3/4-hand sanitizer removal left of stage

1@ 19 1/4x 22 3/8

Armoured One LLC
 386 North Midler Ave.
 Syracuse, NY 13206 US
 +1 3157204186
 ar@armouredone.com
 www.armouredone.com



Quote#: Q-04098

ADDRESS	SHIP TO
Hernando County School District 919 North Broad Street Brooksville FL 34601	Hernando County School District 919 North Broad Street Brooksville FL 34601

Date Provided:

Expires On: 6/30/2026

Purchase Order:

SHIP VIA	Payment Terms	ESTIMATOR	JOB NAME
	Net 30	Joshua Dorschner	Powell Middle School

ACTIVITY	QTY	PRICE	AMOUNT
Film Installation: AOTSF23 SECURITY FILM Main Office Outer Windows - Window : 18 1/4 X 40 3/4	8	\$237.62	\$1,900.96
Film Installation: AOTSF23 SECURITY FILM Main Office Outer Windows - Window : 18 5/8 X 48	1	\$285.65	\$285.65
Film Installation: AOTSF23 SECURITY FILM Main Office Outer Windows - Window : 19 X 48	1	\$291.40	\$291.40
Film Installation: AOTSF23 SECURITY FILM Library - Door : 24 1/4 X 70	4	\$542.37	\$2,169.48
Film Installation: AOTSF23 SECURITY FILM Library - SL : 19 1/8 X 51 1/4	2	\$313.17	\$626.34
Film Installation: AOTSF23 SECURITY FILM Gymnasium - Door : 4 1/2 X 25 3/4	6	\$138.03	\$828.18
Film Installation: AOTSF23 SECURITY FILM Gymnasium Foyer Rear Entrance - Door : 4 1/2 X 25 3/4	2	\$138.03	\$276.06
Film Installation: AOTSF23 SECURITY FILM Gymnasium Main Entrance - Door : 24 1/2 X 67	2	\$524.48	\$1,048.96
Film Installation: AOTSF23 SECURITY FILM Gymnasium Main Entrance - SL : 23 7/8 X 53	2	\$404.31	\$808.62

IMPORTANT: A finance charge of 1.5% per month (18% per annum) will be charged on past due balances.

ACTIVITY	QTY	PRICE	AMOUNT
Film Installation: AOTSF23 SECURITY FILM Gymnasium Main Entrance - SL : 23 7/8 X 26 1/2	2	\$202.15	\$404.30
Film Installation: AOTSF23 SECURITY FILM Cafeteria - Door : 24 1/2 X 69	4	\$540.14	\$2,160.56
Film Installation: AOTSF23 SECURITY FILM Cafeteria - SL : 19 1/4 X 38 3/4	3	\$238.34	\$715.02
Film Installation: AOTSF23 SECURITY FILM Cafeteria - SL : 19 1/4 X 22 3/8	1	\$138.03	\$138.03
Freight	1	\$600.00	\$600.00
Crate	1	\$200.00	\$200.00
Mobility Fee	1	\$1,500.00	\$1,500.00
TOTAL:			\$13,953.56

Total Pieces
38.00

Total Square Feet
235.71

Terms & Conditions

Terms: 60% down to do final measure, fabricate product, and deliver on-site. Balance due upon completion of installation.

Includes all products, installation, and prevailing wage.

** Wood stops are not acceptable for the proper function of Shooter/Attack Certified Security film and may require upgraded vision kits.

***installation on glass blocks is not allowed.

Disclaimer: Armoured One's 23 MIL Shooter Attack Film is not "bullet-proof" or "bullet-resistant". It is designed to slow down an attacker with a gun.

Accepted By: _____

Accepted Date: ____/____/____

Approved as to Legal Sufficiency
Caroline I. Mockler, Esq.
Staff Counsel, HCSD
5:43 pm, 05/14/2026

IMPORTANT: A finance charge of 1.5% per month (18% per annum) will be charged on past due balances.

SPRINGHILL ELEMENTARY SCHOOL

Tim Czyz

Thursday, April 30, 2026

Prepared For Hernando District Schools

10 Issues Identified



ISSUE 1

Assigned To Principals Office

Door 1 @ 2 3/4x 30 7/8



ISSUE 2

Assigned To Building One Entrance 100

Door 4 @ 5x 32 3/4 take apart heavy paint



ISSUE 3

Assigned To Building One By Room 101

Door 4 @ 24 1/2x 69

SL 2 @ 13 1/2x 58 1/4

SL 2 @ 13 1/2x 32

SL 2 @ 35 3/4x 58 1/4

SL 2 @ 35 3/4x 32

The issue includes entrances and side lights at both sides of hallway



ISSUE 4

Assigned To Cafe

Door 2 @ 22 1/8x 30 1/8

Door 2 @ 22 1/8x 21 1/4

SL 1 @ 22 1/2x 40 3/8

SL 1 @ 22 1/2x 32 3/8



ISSUE 5

Assigned To Cafe

Door 2 @ 22 1/8 x 30 1/8

Door 2 @ 22 1/8 x 20 3/4

SL 1 @ 10 1/4 x 40 1/2

SL 1 @ 10 1/4 x 32 3/8

SL 1 @ 32 1/2 x 40 1/2

SL 1 @ 32 1/2 x 32 3/8



ISSUE 6

Assigned To Library

Door 1 @ 25 3/8 x 68- take apart

Door 1 @ 31 1/2 x 35- take apart

Door 1 @ 31 1/2 x 32 1/4- take apart

SL 1 @ 38 1/8 x 33 5/8

SL 1 @ 34 1/4 x 33 7/8- left



ISSUE 7

Assigned To Library Back Door

Door 1 @ 24 1/2 x 66 7/8



ISSUE 8

Assigned To Building Nine Entrance 130

Door 2 @ 25 1/2 x 33 7/8

Door 2 @ 25 1/2 x 28

Hybrid anchoring, take apart on the sides square tops on top and bottom



ISSUE 9

Assigned To Building Nine Entrance 130 Both Ends Of The Hallway

Door 4@ 25 1/2x 33 7/8

Door 4@ 25 1/2x 28

Hybrid anchoring



ISSUE 10

Assigned To Building 14 Entrance Is 001 Both Ends Of Hallway

Door 4@ 8 3/4x 42 3/4

Armoured One LLC
 386 North Midler Ave.
 Syracuse, NY 13206 US
 +1 3157204186
 ar@armouredone.com
 www.armouredone.com



Quote#: Q-04097

ADDRESS

Hernando County School
 District
 919 North Broad Street
 Brooksville
 FL
 34601

SHIP TO

Hernando County School
 District
 919 North Broad Street
 Brooksville
 FL
 34601

Date Provided:

Expires On: 6/30/2026

Purchase Order:

SHIP VIA

Payment Terms
 Net 30

ESTIMATOR
 Joshua Dorschner

JOB NAME
 Springhill Elementary
 School

ACTIVITY	QTY	PRICE	AMOUNT
Film Installation: AOTSF23 SECURITY FILM Building 1 Entrance 100 - Door : 5 X 32 3/4	4	\$138.00	\$552.00
Film Installation: AOTSF23 SECURITY FILM Building 14 Entrance 001 Both Ends of Hallway - Door : 8 3/4 X 42 3/4	4	\$138.00	\$552.00
Film Installation: AOTSF23 SECURITY FILM Building 1 By Room 101 - Door : 24 1/2 X 69	4	\$540.02	\$2,160.08
Film Installation: AOTSF23 SECURITY FILM Building 1 By Room 101 - SL : 13 1/2 X 58 1/4	2	\$251.20	\$502.40
Film Installation: AOTSF23 SECURITY FILM Building 1 By Room 101 - SL : 13 1/2 X 32	2	\$138.00	\$276.00
Film Installation: AOTSF23 SECURITY FILM Building 1 By Room 101 - SL : 35 3/4 X 58 1/4	2	\$665.22	\$1,330.44
Film Installation: AOTSF23 SECURITY FILM Building 1 By Room 101 - SL : 35 3/4 X 32	2	\$365.44	\$730.88
Film Installation: AOTSF23 SECURITY FILM Library Back Door - Door : 24 1/2 X 66 7/8	1	\$523.39	\$523.39
Film Installation: AOTSF23 SECURITY FILM Principals Office - Door : 2 3/4 X 30 7/8	1	\$138.00	\$138.00
Film Installation: AOTSF23 SECURITY FILM Cafe - Door : 22 1/8 X 30 1/8	2	\$212.91	\$425.82

IMPORTANT: A finance charge of 1.5% per month (18% per annum) will be charged on past due balances.

ACTIVITY	QTY	PRICE	AMOUNT
Film Installation: AOTSF23 SECURITY FILM Cafe - Door : 22 1/8 X 21 1/4	2	\$150.19	\$300.38
Film Installation: AOTSF23 SECURITY FILM Cafe - SL : 22 1/2 X 40 3/8	1	\$290.20	\$290.20
Film Installation: AOTSF23 SECURITY FILM Cafe - SL : 22 1/2 X 32 3/8	1	\$232.70	\$232.70
Film Installation: AOTSF23 SECURITY FILM Cafe - Door : 22 1/8 X 30 1/8	2	\$212.91	\$425.82
Film Installation: AOTSF23 SECURITY FILM Cafe - Door : 22 1/8 X 20 3/4	2	\$146.65	\$293.30
Film Installation: AOTSF23 SECURITY FILM Cafe - SL : 10 1/4 X 40 1/2	1	\$138.00	\$138.00
Film Installation: AOTSF23 SECURITY FILM Cafe - SL : 10 1/4 X 32 3/8	1	\$138.00	\$138.00
Film Installation: AOTSF23 SECURITY FILM Cafe - SL : 32 1/2 X 40 1/2	1	\$420.47	\$420.47
Film Installation: AOTSF23 SECURITY FILM Cafe - SL : 32 1/2 X 32 3/8	1	\$336.12	\$336.12
Film Installation: AOTSF23 SECURITY FILM Library - Door : 25 3/8 X 68	1	\$551.20	\$551.20
Film Installation: AOTSF23 SECURITY FILM Library - Door : 31 1/2 X 35	1	\$352.19	\$352.19
Film Installation: AOTSF23 SECURITY FILM Library - Door : 31 1/2 X 32 1/4	1	\$324.52	\$324.52
Film Installation: AOTSF23 SECURITY FILM Library - SL : 38 1/8 X 33 5/8	1	\$409.51	\$409.51
Film Installation: AOTSF23 SECURITY FILM Library - SL : 34 1/4 X 33 7/8	1	\$370.63	\$370.63
Film Installation: AOTSF23 SECURITY FILM Building 9 Entrance 130 - Door : 25 1/2 X 33 7/8	2	\$275.94	\$551.88
Film Installation: AOTSF23 SECURITY FILM Building 9 Entrance 130 - Door : 25 1/2 X 28	2	\$228.08	\$456.16
Film Installation: AOTSF23 SECURITY FILM Building 9 Entrance 130 Both Ends of Hallway - Door : 25 1/2 X 33 7/8	4	\$275.94	\$1,103.76
Film Installation: AOTSF23 SECURITY FILM Building 9 Entrance 130 Both Ends of Hallway - Door : 25 1/2 X 28	4	\$228.08	\$912.32
Freight	1	\$600.00	\$600.00

IMPORTANT: A finance charge of 1.5% per month (18% per annum) will be charged on past due balances.

ACTIVITY	QTY	PRICE	AMOUNT
Crate	1	\$200.00	\$200.00
Mobility Fee	1	\$2,000.00	\$2,000.00
TOTAL:			\$17,598.17

Total Pieces **Total Square Feet**
53.00 **309.42**

Terms & Conditions

Terms: 60% down to do final measure, fabricate product, and deliver on-site. Balance due upon completion of installation.

Includes all products, installation, and prevailing wage.

** Wood stops are not acceptable for the proper function of Shooter/Attack Certified Security film and may require upgraded vision kits.

***installation on glass blocks is not allowed.

Disclaimer: Armoured One's 23 MIL Shooter Attack Film is not "bullet-proof" or "bullet-resistant". It is designed to slow down an attacker with a gun.

Accepted By: _____

Accepted Date: ____/____/____

Approved as to Legal Sufficiency
 Caroline I. Mockler, Esq.
 Staff Counsel, HCSD
 5:43 pm, 05/14/2026

SUNCOAST ELEMENTARY SCHOOL

Tim Czyz

Thursday, April 30, 2026

Prepared For Hernando District Schools

5 Issues Identified



ISSUE 1

Assigned To Cafe

Door 8@ 5 1/2x 20 1/2- take apart clip type

Plexiglass

If the district wants our glass is the same size as film



ISSUE 2

Assigned To Building Eight Entrances On Both End Of The Hallway

Door 4@ 6 1/2x 30 3/4-take apart clip type



ISSUE 3

Assigned To Building Eight Stair Entrances

Door 2@ 3 1/2x 30 3/4- take apart, clip type



ISSUE 4

Assigned To Building Eight Parking Lot Side Entrance

Door 2@ 6 1/2x 30 3/4

Take apart



ISSUE 5

Assigned To Library

Door 2@ 24 1/2x 69

SL 2@ 31 5/8x 59 7/8

SL 2@ 31 5/8x 20 1/4

Dow clean up on inside

Armoured One LLC
 386 North Midler Ave.
 Syracuse, NY 13206 US
 +1 3157204186
 ar@armouredone.com
 www.armouredone.com



Quote#: Q-04099

ADDRESS	SHIP TO
Hernando County School District 919 North Broad Street Brooksville FL 34601	Hernando County School District 919 North Broad Street Brooksville FL 34601

Date Provided:

Expires On: 6/30/2026

Purchase Order:

SHIP VIA	Payment Terms	ESTIMATOR	JOB NAME
	Net 30	Joshua Dorschner	Suncoast Elementary School

ACTIVITY	QTY	PRICE	AMOUNT
Film Installation: AOTSF23 SECURITY FILM Cafe - Door : 5 1/2 X 20 1/2	8	\$138.18	\$1,105.44
Film Installation: AOTSF23 SECURITY FILM Building 8 Entrances on Both Ends of Hallway - Door : 6 1/2 X 30 3/4	4	\$138.18	\$552.72
Film Installation: AOTSF23 SECURITY FILM Building 8 Stair Entrances - Door : 3 1/2 X 30 3/4	2	\$138.18	\$276.36
Film Installation: AOTSF23 SECURITY FILM Building 8 Parking Lot Side Entrance - Door : 6 1/2 X 30 3/4	2	\$138.18	\$276.36
Film Installation: AOTSF23 SECURITY FILM Library - Door : 24 1/2 X 69	2	\$540.73	\$1,081.46
Film Installation: AOTSF23 SECURITY FILM Library - SL : 31 5/8 X 59 7/8	2	\$605.67	\$1,211.34
Film Installation: AOTSF23 SECURITY FILM Library - SL : 31 5/8 X 20 1/4	2	\$204.84	\$409.68
Freight	1	\$600.00	\$600.00
Crate	1	\$200.00	\$200.00
Mobility Fee	1	\$800.00	\$800.00
TOTAL:			\$6,513.36

IMPORTANT: A finance charge of 1.5% per month (18% per annum) will be charged on past due balances.

Total Pieces
22.00

Total Square Feet
74.76

Terms & Conditions

Terms: 60% down to do final measure, fabricate product, and deliver on-site. Balance due upon completion of installation.

Includes all products, installation, and prevailing wage.

** Wood stops are not acceptable for the proper function of Shooter/Attack Certified Security film and may require upgraded vision kits.

***installation on glass blocks is not allowed.

Disclaimer: Armoured One's 23 MIL Shooter Attack Film is not "bullet-proof" or "bullet-resistant". It is designed to slow down an attacker with a gun.

Accepted By: _____

Accepted Date: ____/____/____

Approved as to Legal Sufficiency
Caroline I. Mockler, Esq.
Staff Counsel, HCSD
5:43 pm, 05/14/2026

WEEKI WACHEE HIGH SCHOOL

Tim Czyz

Monday, May 4, 2026

Prepared For Fernando District Schools

19 Issues Identified



ISSUE 1

Assigned To 300 Hallway Doors

Door 6@ 19 5/8x 29 3/4

Door 6@ 19 5/8x 22 3/4



ISSUE 2

Assigned To 300 Doors By Stairwell

Door 2@ 19 3/4x 29 3/4

Door 2@ 19 3/4x 22 3/4



ISSUE 3

Assigned To 600 Holli Second Floor

Door 6@ 19 3/4x 29 3/4

Door 6@ 19 3/4x 23 3/4

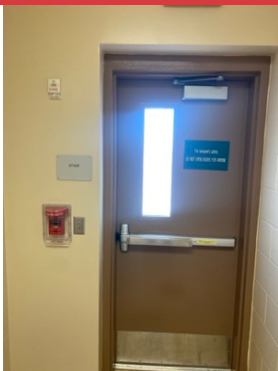

ISSUE 4

Assigned To Entrance By 1-605 Second Floor

Door 1@ 7 3/4x 29 3/4



ISSUE 5

Assigned To Library

Door 2@ 19 3/4x 29 3/4

Door 2@ 19 3/4x 22 3/4

Windows 3@ 37 1/4x 40 1/2

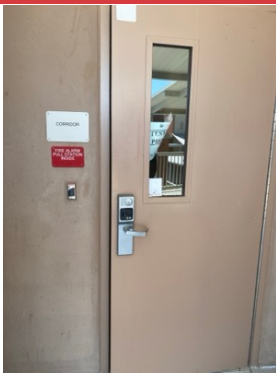

ISSUE 6

Assigned To Library

Door 2@ 7 3/4x 29 3/4



ISSUE 7

Assigned To 500 Hallway Second Floor

Door 6@ 19 3/4x 29 3/4

Door 6@ 19 3/4x 22 3/4



ISSUE 8

Assigned To Entrance By 1-505 Second Floor

Door 1@ 7 3/4x 29 3/4



ISSUE 9

Assigned To 200 Rear Entrance Stairwell

Door 2@ 19 3/4x 29 3/4

Door 2@ 19 3/4x 22 3/4



ISSUE 10

Assigned To 200 Hallway Doors

Door 6@ 19 3/4x 29 3/4

Door 6@ 19 3/4x 22 3/4



ISSUE 11

Assigned To Entrance 2–253 Fine Arts

Door 2@ 19 3/4x 29 3/4

Door 2@ 19 3/4x 22 3/4

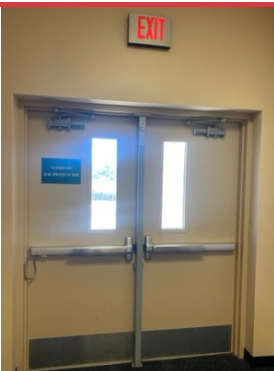

ISSUE 12

Assigned To Entrance By 2–234 Fine Arts Building

Door 2@ 7 3/4x 29 3/4



ISSUE 13

Assigned To Entrance By Teacher Dining Building Two
Door 2@ 7 3/4x 29 3/4



ISSUE 14

Assigned To Café
Door 8@ 19 3/4x 29 3/4
Door 8@ 19 3/4x 22 3/4
SI 8@ 25 1/2x 46 1/2
SI 8@ 25 1/2x 30 1/4



ISSUE 15

Assigned To Gymnasium Main Entrance
Door 10@ 19 3/4x 29 3/4
Door 10 @ 19 3/4x 22 3/4
SL 6@ 12 1/2x 46 1/2
SL 6@ 12 1/2x 30 3/8



ISSUE 16

Assigned To Gymnasium
Door 6@ 7 3/4x 29 3/4



ISSUE 17

Assigned To Kitchen

Door 2 @ 7 3/4x 29 3/4



ISSUE 18

Assigned To Rm 1-301

Door 1 @ 7 3/4x 29 3/4



ISSUE 19

Assigned To Replacement Pieces Main Entrance Area

3 @ 31 3/8x 46 1/2

2 @ 31 3/8x 30 1/4

Water bubbles on bottom of film was not pushed out enough

Armoured One LLC
 386 North Midler Ave.
 Syracuse, NY 13206 US
 +1 3157204186
 ar@armouredone.com
 www.armouredone.com



Quote#: Q-04164

ADDRESS	SHIP TO
Hernando County School District 919 North Broad Street Brooksville FL 34601	Hernando County School District 919 North Broad Street Brooksville FL 34601

Date Provided:

Expires On: 6/30/2026

Purchase Order:

SHIP VIA	Payment Terms	ESTIMATOR	JOB NAME
	Net 30	Joshua Dorschner	Weeki Wachee High School

ACTIVITY	QTY	PRICE	AMOUNT
Film Installation: AOTSF23 SECURITY FILM 300 Doors By Stairwell - Door : 19 3/4 X 29 3/4	2	\$187.69	\$375.38
Film Installation: AOTSF23 SECURITY FILM 300 Doors By Stairwell - Door : 19 3/4 X 22 3/4	2	\$143.53	\$287.06
Film Installation: AOTSF23 SECURITY FILM Library - Door : 19 3/4 X 29 3/4	2	\$187.69	\$375.38
Film Installation: AOTSF23 SECURITY FILM Library - Door : 19 3/4 X 22 3/4	2	\$143.53	\$287.06
Film Installation: AOTSF23 SECURITY FILM 300 Highway - Door : 19 5/8 X 29 3/4	6	\$186.51	\$1,119.06
Film Installation: AOTSF23 SECURITY FILM 300 Highway - Door : 19 5/8 X 22 3/4	6	\$142.62	\$855.72
Film Installation: AOTSF23 SECURITY FILM Ent By 1-605 Second FI - Door : 7 3/4 X 29 3/4	1	\$138.00	\$138.00
Film Installation: AOTSF23 SECURITY FILM Library - Door : 7 3/4 X 29 3/4	2	\$138.00	\$276.00
Film Installation: AOTSF23 SECURITY FILM Ent By 1-505 Second FI - Door : 7 3/4 X 29 3/4	1	\$138.00	\$138.00
Film Installation: AOTSF23 SECURITY FILM Gym Main Ent - Door : 19 3/4 X 29 3/4	10	\$187.69	\$1,876.90

IMPORTANT: A finance charge of 1.5% per month (18% per annum) will be charged on past due balances.

ACTIVITY	QTY	PRICE	AMOUNT
Film Installation: AOTSF23 SECURITY FILM Gym Main Ent - Door : 19 3/4 X 22 3/4	10	\$143.53	\$1,435.30
Film Installation: AOTSF23 SECURITY FILM Gym Main Ent - SL : 12 1/2 X 46 1/2	6	\$185.68	\$1,114.08
Film Installation: AOTSF23 SECURITY FILM Gym Main Ent - SL : 12 1/2 X 30 3/8	6	\$138.00	\$828.00
Film Installation: AOTSF23 SECURITY FILM Kitchen - Door : 7 3/4 X 29 3/4	2	\$138.00	\$276.00
Film Installation: AOTSF23 SECURITY FILM 200 Rear Ent Stairwell - Door : 19 3/4 X 29 3/4	2	\$187.69	\$375.38
Film Installation: AOTSF23 SECURITY FILM 200 Rear Ent Stairwell - Door : 19 3/4 X 22 3/4	2	\$143.53	\$287.06
Film Installation: AOTSF23 SECURITY FILM 200 Hallway - Door : 19 3/4 X 29 3/4	6	\$187.69	\$1,126.14
Film Installation: AOTSF23 SECURITY FILM 200 Hallway - Door : 19 3/4 X 22 3/4	6	\$143.53	\$861.18
Film Installation: AOTSF23 SECURITY FILM Entrance 2-253 Fine Arts - Door : 19 3/4 X 29 3/4	2	\$187.69	\$375.38
Film Installation: AOTSF23 SECURITY FILM Entrance 2-253 Fine Arts - Door : 19 3/4 X 22 3/4	2	\$143.53	\$287.06
Film Installation: AOTSF23 SECURITY FILM Entrance By 2-234 Fine Arts Building - Door : 7 3/4 X 29 3/4	2	\$138.00	\$276.00
Film Installation: AOTSF23 SECURITY FILM Entrance By Teacher Dining Building Two - Door : 7 3/4 X 29 3/4	2	\$138.00	\$276.00
Film Installation: AOTSF23 SECURITY FILM Cafe - Door : 19 3/4 X 29 3/4	8	\$187.69	\$1,501.52
Film Installation: AOTSF23 SECURITY FILM Cafe - Door : 19 3/4 X 22 3/4	8	\$143.53	\$1,148.24
Film Installation: AOTSF23 SECURITY FILM Cafe - SL : 25 1/2 X 46 1/2	8	\$378.78	\$3,030.24
Film Installation: AOTSF23 SECURITY FILM Cafe - SL : 25 1/2 X 30 1/4	8	\$246.41	\$1,971.28
Film Installation: AOTSF23 SECURITY FILM Gym - Door : 7 3/4 X 29 3/4	6	\$138.00	\$828.00
Film Installation: AOTSF23 SECURITY FILM Kitchen - Door : 7 3/4 X 29 3/4	2	\$138.00	\$276.00

IMPORTANT: A finance charge of 1.5% per month (18% per annum) will be charged on past due balances.

ACTIVITY	QTY	PRICE	AMOUNT
Film Installation: AOTSF23 SECURITY FILM Rm 1-301 - Door : 7 3/4 X 29 3/4	1	\$138.00	\$138.00
Freight	1	\$600.00	\$600.00
Crate	1	\$200.00	\$200.00
Mobility Fee	1	\$2,600.00	\$2,600.00
		TOTAL:	\$25,539.42

Total Pieces
123.00

Total Square Feet
452.54

Terms & Conditions

Terms: 60% down to do final measure, fabricate product, and deliver on-site. Balance due upon completion of installation.

Includes all products, installation, and prevailing wage.

** Wood stops are not acceptable for the proper function of Shooter/Attack Certified Security film and may require upgraded vision kits.

***installation on glass blocks is not allowed.

Disclaimer: Armoured One's 23 MIL Shooter Attack Film is not "bullet-proof" or "bullet-resistant". It is designed to slow down an attacker with a gun.

Accepted By: _____

Accepted Date: ____/____/____

Approved as to Legal Sufficiency

Caroline I. Mockler, Esq.
Staff Counsel, HCSD

5:43 pm, 05/14/2026

IMPORTANT: A finance charge of 1.5% per month (18% per annum) will be charged on past due balances.

WEST HERNANDO MIDDLE SCHOOL

Tim Czyz

Tuesday, April 28, 2026

Prepared For Hernando District Schools

11 Issues Identified



ISSUE 1

Assigned To Administration Courtyard, Windows
3@ 41 3/8x 32 1/8- b5.



ISSUE 2

Assigned To Building One Parking Side
14@ 29 5/8x 32 1/8



ISSUE 3

Assigned To Building One Side Door
Door 1 @ 9x 38 5/8- take apart, heavy paint



ISSUE 4

Assigned To Building Two Next To Electrical
2@ 29 5/8x 32 1/8



ISSUE 5

Assigned To Building Five Guidance

Door 1 @ 9x 39- take apart, heavy windows

Window 2 @ 29 5/8x 32 1/8



ISSUE 6

Assigned To Building Five Parking Side

10 @ 29 5/8x 32 1/8



ISSUE 7

Assigned To Entrance By 552 Electrical

Door 1 @ 18 3/4x 61 take apart heavy paint



ISSUE 8

Assigned To Entrance By Teachers Dining

Door 2 @ 19x 61- take apart heavy paint



ISSUE 9

Assigned To Entrance By 509 Electrical
Door 2@ 19x 61- take apart heavy paint



ISSUE 10

Assigned To Café Parking Lot Side
Door 4@ 19x 61- take apart, heavy paint
Windows 4@ 29 5/8x 32 1/8
Film removal



ISSUE 11

Assigned To Building Six Parking Lot Side Entrance
Door 2@ 19x 61- take apart

Armoured One LLC
 386 North Midler Ave.
 Syracuse, NY 13206 US
 +1 3157204186
 ar@armouredone.com
 www.armouredone.com



Quote#: Q-04145

ADDRESS

Hernando County School District
 919 North Broad Street
 Brooksville
 FL
 34601

SHIP TO

Hernando County School District
 919 North Broad Street
 Brooksville
 FL
 34601

Date Provided:

Expires On: 6/30/2026

Purchase Order:

SHIP VIA

Payment Terms
 Net 30

ESTIMATOR
 Joshua Dorschner

JOB NAME
 West Hernando Middle School

ACTIVITY	QTY	PRICE	AMOUNT
Film Installation: AOTSF23 SECURITY FILM Ent BY 509 Electrical - Door : 19 X 61	2	\$394.62	\$789.24
Film Installation: AOTSF23 SECURITY FILM Buidling 1 Side - Door : 9 X 38 5/8	1	\$147.09	\$147.09
Film Installation: AOTSF23 SECURITY FILM Building 5 Guidance - Door : 9 X 39	1	\$147.09	\$147.09
Film Installation: AOTSF23 SECURITY FILM Ent By 552 Electrical - Door : 18 3/4 X 61	1	\$389.43	\$389.43
Film Installation: AOTSF23 SECURITY FILM Ent By Teacher Dining - Door : 19 X 61	2	\$394.62	\$789.24
Film Installation: AOTSF23 SECURITY FILM Cafe Parking Lot Side - Door : 19 X 61	4	\$394.62	\$1,578.48
Film Installation: AOTSF23 SECURITY FILM Building 6 Parking Lot Side Ent - Door : 19 X 61	2	\$394.62	\$789.24
Freight	1	\$200.00	\$200.00
Crate	1	\$600.00	\$600.00
Mobility Fee	1	\$900.00	\$900.00
TOTAL:			\$6,329.81

Total Pieces
13.00

Total Square Feet
93.28

Terms & Conditions

Terms: 60% down to do final measure, fabricate product, and deliver on-site. Balance due upon completion of installation.

Includes all products, installation, and prevailing wage.

** Wood stops are not acceptable for the proper function of Shooter/Attack Certified Security film and may require upgraded vision kits.

***installation on glass blocks is not allowed.

Disclaimer: Armoured One's 23 MIL Shooter Attack Film is not "bullet-proof" or "bullet-resistant". It is designed to slow down an attacker with a gun.

Accepted By: _____

Accepted Date: ____/____/____

Approved as to Legal Sufficiency

Caroline I. Mockler, Esq.
Staff Counsel, HCSD

5:43 pm, 05/14/2026

WESTSIDE ELEMENTARY SCHOOL

Tim Czyz

Wednesday, April 29, 2026

Prepared For Hernando District Schools

5 Issues Identified



ISSUE 1

Assigned To Building Two Library Entrance 200
Door 2@ 26 7/8x 71 3/4



ISSUE 2

Assigned To Building One Entrance By Room 130
Door 2@ 26 7/8x 71 3/4
SL 2@ 8 3/8x 45 1/2
SL 2@ 8 3/8x 34



ISSUE 3

Assigned To Building One Entrance Near Room 171
Door 2@ 27x 71 7/8
SL 2@ 8 1/4x 45 1/2-top stops are missing
SL 2@ 8 1/4 x 34 1/4



ISSUE 4

Assigned To Building One Entrance By Room 131
Door 2@ 27x 71 7/8
SL 2@ 8 1/4x 45 1/2
SL 2@ 8 1/4x 34



ISSUE 5

Assigned To Building One Entrance By Room 127

Door 2@ 26 7/8x 71 7/8

SL 2@ 8x 54 3/8

SL 8x 34

Armoured One LLC
 386 North Midler Ave.
 Syracuse, NY 13206 US
 +1 3157204186
 ar@armouredone.com
 www.armouredone.com



Quote#: Q-04087

ADDRESS

Hernando County School District
 919 North Broad Street
 Brooksville
 FL
 34601

SHIP TO

Hernando County School District
 919 North Broad Street
 Brooksville
 FL
 34601

Date Provided:

Expires On: 6/30/2026

Purchase Order:

SHIP VIA

Payment Terms
 Net 30

ESTIMATOR
 Joshua Dorschner

JOB NAME
 Westside Elementary School

ACTIVITY	QTY	PRICE	AMOUNT
Film Installation: AOTSF23 SECURITY FILM Building 1 Entrance by Room 127 - Door : 26 7/8 X 71 7/8	2	\$618.53	\$1,237.06
Film Installation: AOTSF23 SECURITY FILM Building 1 Entrance by Room 127 - SL : 8 X 54 3/8	2	\$139.29	\$278.58
Film Installation: AOTSF23 SECURITY FILM Building 1 Entrance by Room 127 - SL : 8 X 34	2	\$138.33	\$276.66
Film Installation: AOTSF23 SECURITY FILM Building 2 Library Entrance 200 - Door : 26 7/8 X 71 3/4	2	\$617.45	\$1,234.90
Film Installation: AOTSF23 SECURITY FILM Building 1 Entrance by Room 130 - Door : 26 7/8 X 71 3/4	2	\$617.45	\$1,234.90
Film Installation: AOTSF23 SECURITY FILM Building 1 Entrance by Room 130 - SL : 8 3/8 X 45 1/2	2	\$138.33	\$276.66
Film Installation: AOTSF23 SECURITY FILM Building 1 Entrance by Room 130 - SL : 8 3/8 X 34	2	\$138.33	\$276.66
Film Installation: AOTSF23 SECURITY FILM Building 1 Entrance by Room 131 - Door : 27 X 71 7/8	2	\$621.40	\$1,242.80

IMPORTANT: A finance charge of 1.5% per month (18% per annum) will be charged on past due balances.

ACTIVITY	QTY	PRICE	AMOUNT
Film Installation: AOTSF23 SECURITY FILM Building 1 Entrance by Room 131 - SL : 8 1/4 X 45 1/2	2	\$138.33	\$276.66
Film Installation: AOTSF23 SECURITY FILM Building 1 Entrance by Room 131 - SL : 8 1/4 X 34	2	\$138.33	\$276.66
Film Installation: AOTSF23 SECURITY FILM Building 1 Entrance Near Room 171 - Door : 27 X 71 7/8	2	\$621.40	\$1,242.80
Film Installation: AOTSF23 SECURITY FILM Building 1 Entrance Near Room 171 - SL : 8 1/4 X 45 1/2	2	\$138.33	\$276.66
Film Installation: AOTSF23 SECURITY FILM Building 1 Entrance Near Room 171 - SL : 8 1/4 X 34 1/4	2	\$138.33	\$276.66
Freight	1	\$600.00	\$600.00
Crate	1	\$200.00	\$200.00
Mobility Fee	1	\$900.00	\$900.00
TOTAL:			\$10,107.66

Total Pieces
26.00

Total Square Feet
171.61

Terms & Conditions

Terms: 60% down to do final measure, fabricate product, and deliver on-site. Balance due upon completion of installation.

Includes all products, installation, and prevailing wage.

** Wood stops are not acceptable for the proper function of Shooter/Attack Certified Security film and may require upgraded vision kits.

***installation on glass blocks is not allowed.

Disclaimer: Armoured One's 23 MIL Shooter Attack Film is not "bullet-proof" or "bullet-resistant". It is designed to slow down an attacker with a gun.

Accepted By: _____

Accepted Date: ____/____/____

Approved as to Legal Sufficiency

Caroline I. Mockler, Esq.
Staff Counsel, HCSD

5:42 pm, 05/14/2026

WINDING WATERS K8

Tim Czyz

Monday, May 4, 2026

Prepared For Hernando District Schools

13 Issues Identified

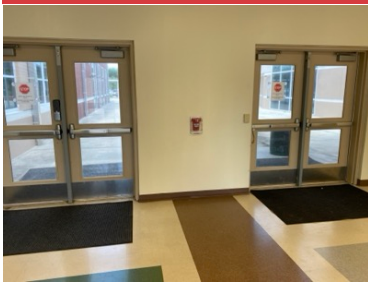

ISSUE 1

Assigned To Entrance By Café

8@ 22 3/4x 32 3/4

8@ 22 3/4x 23 1/2

Take apart, clip type

Doors are across from each other in hallway



ISSUE 2

Assigned To Café

Door 6@ 22 3/4x 32 1/2

Door 6@ 22 3/4x 23 1/2 take apart clip type



ISSUE 3

Assigned To Ent Off The Back Of The Stage

Door 2@ 22 1/2x 32 1/2

Door 2@ 22 1/2x 23 3/4

Kick park clip type



ISSUE 4

Assigned To Entrance By 01-424 Custodial Receiving

Door 2@ 6 1/2x 33 1/2

Take apart clip type



ISSUE 5

Assigned To Entrance By Art Room 01-418

Door 2@ 6 1/2x 33 1/2

Take apart, clip type



ISSUE 6

Assigned To 05-513 Stairwell Entrance

Door 2@ 6 1/2x 33 1/2

Take apart, clip type

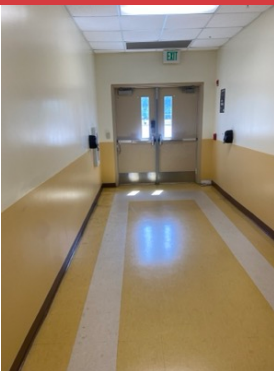

ISSUE 7

Assigned To Entrance Base 01-514

Door 2@ 6 1/2x 33 1/2

Take apart, clip type



ISSUE 8

Assigned To 01-519 Stairwell

Door 2@ 6 1/2x 33 1/2

Take apart



ISSUE 9

Assigned To 01-538 Stairwell Entrance

Door 2@ 6 1/2x 33 1/2

Take apart, clip type



ISSUE 10

Assigned To Ent By Gym In Hallway

Door 8@ 26 1/8x 71 1/4

SL 2@ 27 7/8x 47 3/4

SL 2@ 27 7/8x 31 3/4

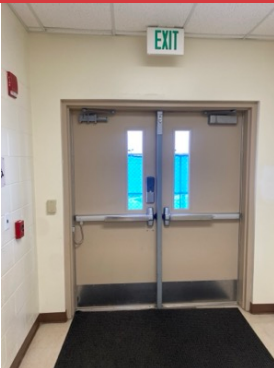

ISSUE 11

Assigned To Entrance By 06-612 Off Gymnasium

Door 2@ 6 1/2x 33 1/2

Take apart, clip type



ISSUE 12

Assigned To Entrance By Concession Stand Gymnasium Area

Door 2@ 22 1/2x 33 1/2

Door 2@ 22 1/2x 23 1/2

Take apart, clip type



ISSUE 13

Assigned To Building Two First And Second Floor Hallway
Entrances

Door 8@ 7x 34 3/4

Take apart

Armoured One LLC
 386 North Midler Ave.
 Syracuse, NY 13206 US
 +1 3157204186
 ar@armouredone.com
 www.armouredone.com



Quote#: Q-04128

ADDRESS

Hernando County School District
 919 North Broad Street
 Brooksville
 FL
 34601

SHIP TO

Hernando County School District
 919 North Broad Street
 Brooksville
 FL
 34601

Date Provided:

Expires On: 6/30/2026

Purchase Order:

SHIP VIA

Payment Terms
 Net 30

ESTIMATOR
 Joshua Dorschner

JOB NAME
 Winding Waters K8

ACTIVITY	QTY	PRICE	AMOUNT
Film Installation: AOTSF23 SECURITY FILM Ent By Cafe - Door- clip type : 22 3/4 X 32 3/4	8	\$238.06	\$1,904.48
Film Installation: AOTSF23 SECURITY FILM Ent By Cafe - Door- clip type : 22 3/4 X 23 1/2	8	\$170.82	\$1,366.56
Film Installation: AOTSF23 SECURITY FILM Cafe - Door- clip type : 22 3/4 X 32 1/2	6	\$236.24	\$1,417.44
Film Installation: AOTSF23 SECURITY FILM Cafe - Door : 22 3/4 X 23 1/2	6	\$170.82	\$1,024.92
Film Installation: AOTSF23 SECURITY FILM Entrance By 01-424 Custodial Receiving - Door : 6 1/2 X 33 1/2	2	\$138.03	\$276.06
Film Installation: AOTSF23 SECURITY FILM Assigned To Ent Off The Back Of The Stage - Door : 22 1/2 X 32 1/2	6	\$233.64	\$1,401.84
Film Installation: AOTSF23 SECURITY FILM Assigned To Ent Off The Back Of The Stage - Door : 22 1/2 X 23 3/4	6	\$170.74	\$1,024.44
Film Installation: AOTSF23 SECURITY FILM Entrance By Art Room 01-418 - Door : 6 1/2 X 33 1/2	2	\$138.03	\$276.06
Film Installation: AOTSF23 SECURITY FILM Ent Base 01-514 - Door : 6 1/2 X 33 1/2	2	\$138.03	\$276.06

IMPORTANT: A finance charge of 1.5% per month (18% per annum) will be charged on past due balances.

ACTIVITY	QTY	PRICE	AMOUNT
Film Installation: AOTSF23 SECURITY FILM Entrance By Concession Stand Gymnasium Area - Door : 22 1/2 X 33 1/2	2	\$240.83	\$481.66
Film Installation: AOTSF23 SECURITY FILM Entrance By Concession Stand Gymnasium Area - Door : 22 1/2 X 23 1/2	2	\$168.94	\$337.88
Film Installation: AOTSF23 SECURITY FILM 05-513 Stairwell Entrance - Door : 6 1/2 X 33 1/2	2	\$138.03	\$276.06
Film Installation: AOTSF23 SECURITY FILM 01-519 Stairwell - Door : 6 1/2 X 33 1/2	2	\$138.03	\$276.06
Film Installation: AOTSF23 SECURITY FILM 01-538 Stairwell Entrance - Door : 6 1/2 X 33 1/2	2	\$138.03	\$276.06
Film Installation: AOTSF23 SECURITY FILM Ent By Gym In Hallway - Door : 26 1/8 X 71 1/4	8	\$594.75	\$4,758.00
Film Installation: AOTSF23 SECURITY FILM Ent By Gym In Hallway - SL : 27 7/8 X 47 3/4	2	\$425.28	\$850.56
Film Installation: AOTSF23 SECURITY FILM Ent By Gym In Hallway - SL : 27 7/8 X 31 3/4	2	\$282.78	\$565.56
Film Installation: AOTSF23 SECURITY FILM Entrance By 06-612 Off Gymnasium - Door : 6 1/2 X 33 1/2	2	\$138.03	\$276.06
Film Installation: AOTSF23 SECURITY FILM Building Two First And Second Floor Hallway Ent - Door : 7 X 34 3/4	8	\$138.03	\$1,104.24
Freight	1	\$600.00	\$600.00
Crate	1	\$200.00	\$200.00
Mobility Fee	1	\$2,000.00	\$2,000.00
TOTAL:			\$20,970.00

Total Pieces
78.00

Total Square Feet
363.60

Terms & Conditions

IMPORTANT: A finance charge of 1.5% per month (18% per annum) will be charged on past due balances.

Terms: 60% down to do final measure, fabricate product, and deliver on-site. Balance due upon completion of installation.

Includes all products, installation, and prevailing wage.

** Wood stops are not acceptable for the proper function of Shooter/Attack Certified Security film and may require upgraded vision kits.

***installation on glass blocks is not allowed.

Disclaimer: Armoured One's 23 MIL Shooter Attack Film is not "bullet-proof" or "bullet-resistant". It is designed to slow down an attacker with a gun.

Accepted By: _____

Accepted Date: ____/____/____

Approved as to Legal Sufficiency

Caroline I. Mockler, Esq.
Staff Counsel, HCSD

5:42 pm, 05/14/2026

IMPORTANT: A finance charge of 1.5% per month (18% per annum) will be charged on past due balances.



ARMOURIED ONE